

SINGLE PIPE ROLL

1B

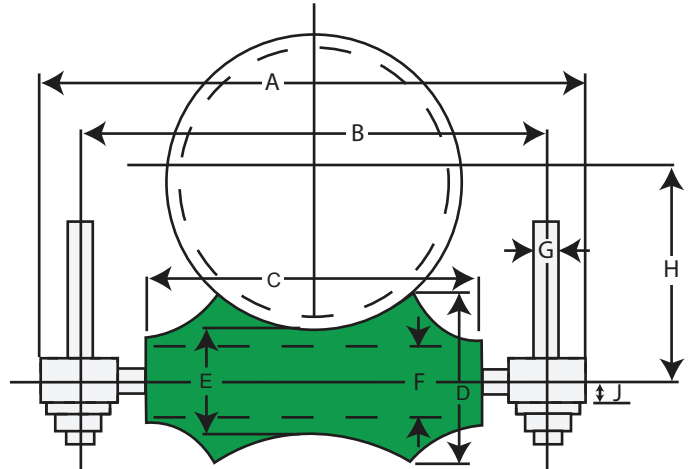
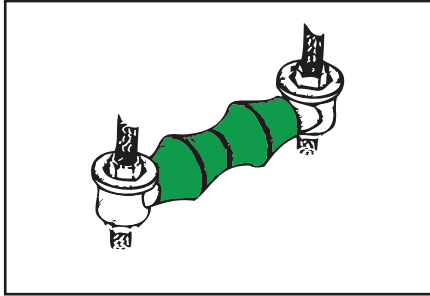

SINGLE PIPE ROLL INCLUDES:
 2 ADJUSTABLE SOCKETS
 1 ROLL AXLE

SPECIFICATIONS MAY VARY - All Dimensions in inches

Pipe Size	G Rod Size	Adj. Socket No.	Max. Load lbs.	Wt. lbs/ea.	A	B*	C	D	E	Axle F	H	J
2	3/8	#1-3/8	600	.57	5 1/4	4 1/8	2 5/8	1 3/16	3/4	3/8	1 5/8	9/16
3	1/2	#2-1/2	700	1.1	6 7/8	5 1/2	3 3/4	1 7/16	7/8	1/2	2 1/4	11/16
4	5/8	#3-1/2 #2A	750	1.7	8 1/4	6 3/4	4 3/4	1 3/4	1	1/2	2 13/16	3/4
5	5/8	#3-1/2 #3-5/8	750	2.6	9 11/16	8 1/16	5 13/16	2	1 1/8	1/2 *5/8	3 7/16	7/8
6	3/4	#4-3/4	1070	4.5	11 7/16	9 9/16	6 7/8	2 5/16	1 1/4	3/4	4	1
8	7/8	#5-7/8	1350	7.2	14 1/16	11 15/16	8 7/8	2 13/16	1 1/2	7/8	5 1/8	1 1/8
10	7/8	#5-7/8	1730	9.5	16 3/16	14 1/16	11	3 3/8	1 3/4	7/8	6 3/8	1 1/8
12	7/8	*#5-7/8 #5-1	2400	15.9	18 1/16	16 1/8	12 1/2	3 7/8	2	*7/8 1	7 7/16	1 1/4
14	1	#6-11/8 #7A	3130	24.3	20 1/8	17 3/4	14 1/4	4 5/8	2 1/2	1 1/8	8 3/8	1 3/8
16	1	#6-11/4 #7A	3970	31.9	22 1/8	19 3/4	16 1/4	5	2 5/8	1 1/4	9 7/16	1 1/2
18	1	#6-11/4 #7A	4200	35.5	24 1/2	21 7/8	18 1/4	5 7/16	2 3/4	1 1/4	10 1/2	1 1/2
20	1 1/4	#8-11/4	4550	47.0	27 1/4	24 1/4	20 1/4	6	3	1 1/4	11 5/8	1 5/8
24	1 1/2	#9-11/2	6160	76.3	32 1/8	28 5/8	24 1/4	7 3/16	3 5/8	1 1/2	14	1 3/4
30	1 1/2	#10-13/4	7290	129.9	39	35 1/2	30 1/4	8 15/16	4 1/2	1 3/4	17 7/16	2 7/16

*Axle lengths may affect B dimension. Contact supplier before pre drilling holes.

*Standard Stock