

ADJUSTABLE ROLL SUPPORT

2B

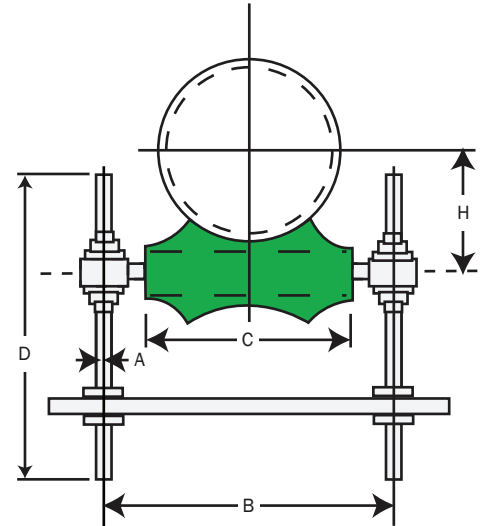
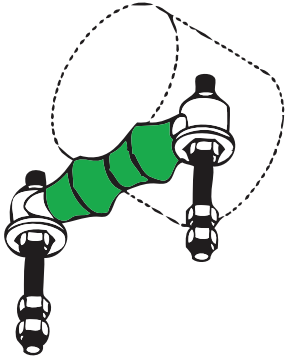

ADJUSTABLE ROLL SUPPORT INCLUDES:

2 ADJUSTABLE SOCKETS - 1 ROLL AXLE

2 VERTICAL THREADED RODS - 8 HEX NUTS

1 CAST IRON ROLL (OMIT WHEN ORDERING NON-CONDUCTIVE ROLLER)

SPECIFICATIONS MAY VARY - All Dimensions in inches

Pipe Size	Wt. lbs/ea.	A Rod Size	*B	C	D	H	Axle Dia.
2	1.3	3/8	4 1/8	2 5/8	12	1 5/8	3/8
3	2.4	1/2	5 1/2	3 3/4	12	2 1/4	1/2
4	3.8	5/8	6 3/4	4 3/4	12	2 13/16	1/2
5	4.7	5/8	8 1/16	5 13/16	12	3 7/16	1/2 *5/8
6	7.6	3/4	9 9/16	6 7/8	12	4	3/4
8	11.0	7/8	11 15/16	8 7/8	12	5 1/8	7/8
10	13.7	7/8	14 1/16	11	12	6 3/8	7/8
12	19.4	7/8	16 1/8	12 1/2	12	7 7/16	*7/8 1
14	31.2	1	17 3/4	14 1/4	18	8 3/8	1 1/8
16	42.5	1	19 3/4	16 1/4	18	9 7/16	1 1/4
18	46.6	1	21 7/8	18 1/4	18	10 1/2	1 1/4
20	66.2	1 1/4	24 1/4	20 1/4	18	11 5/8	1 1/4
24	102.5	1 1/2	28 5/8	24 1/4	24	14	1 1/2
30	186.8	1 3/4	35 1/2	30 1/4	24	17 7/16	1 3/4

*Axle lengths may affect B dimension. Contact supplier before pre drilling holes.

*Standard Stock