

ADJUSTABLE ROLL GUIDE

3B

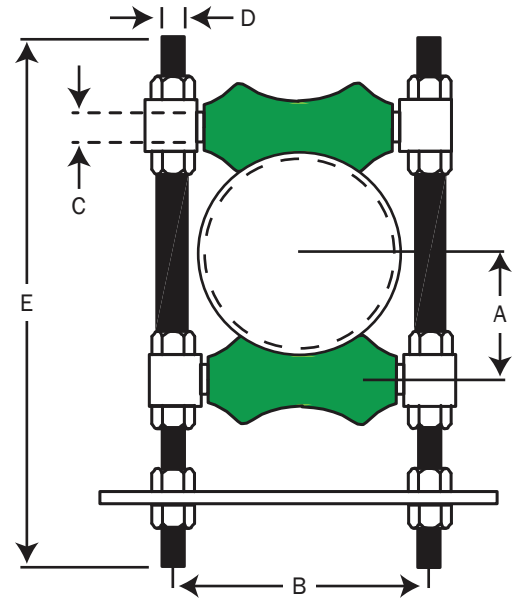
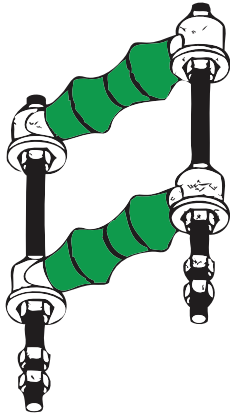

ADJUSTABLE ROLL GUIDE INCLUDES:

- 4 ADJUSTABLE SOCKETS
- 2 ROLL AXLES
- 2 VERTICAL THREADED RODS
- 12 HEX NUTS
- 2 CAST IRON ROLLS (OMIT WHEN ORDERING NON-CONDUCTIVE ROLLERS)

SPECIFICATIONS MAY VARY - All Dimensions in inches

Pipe Size	A	*B	Axle C	Rod Size D	E	Socket No.	Max. Load lbs.	Wt. lbs/ea.
2	1 9/16	4 1/8	3/8	3/8	12	#1-3/8	600	2.15
3	2 3/16	5 1/2	1/2	1/2	14	#2-1/2	700	4.34
4	2 3/4	6 3/4	1/2	5/8	18	#3-1/2	750	6.73
5	3 7/16	8 1/16	1/2 *5/8	5/8	18	#3-1/2 #3-5/8	750	8.95
6	4	9 9/16	3/4	3/4	24	#4-3/4	1070	14.59
8	5 1/4	11 15/16	7/8	7/8	24	#5-7/8	1350	24.33
10	6 1/4	14 1/16	7/8	7/8	30	#5-7/8	1730	27.7
12	7 7/16	16 1/8	*7/8 1	7/8	30	#5-7/8 #5-1	2400	39.62
14	8 5/16	17 3/4	1 1/8	1	36	#6-1 1/8	3130	57.61
16	9 3/8	19 3/4	1 1/4	1	36	#6-1 1/4	3970	87.57
18	10 3/8	21 7/8	1 1/4	1	42	#6-1 1/4	4200	99.54
20	11 1/2	24 1/4	1 1/4	1 1/4	42	#8-1 1/4	4550	131.82
24	13 13/16	28 5/8	1 1/2	1 1/2	42	#9-1 1/2	6160	219.74

*Axle lengths may affect B dimension. Contact supplier before pre drilling holes.

*Standard Stock