

# SPRING CUSHION HANGER

5B

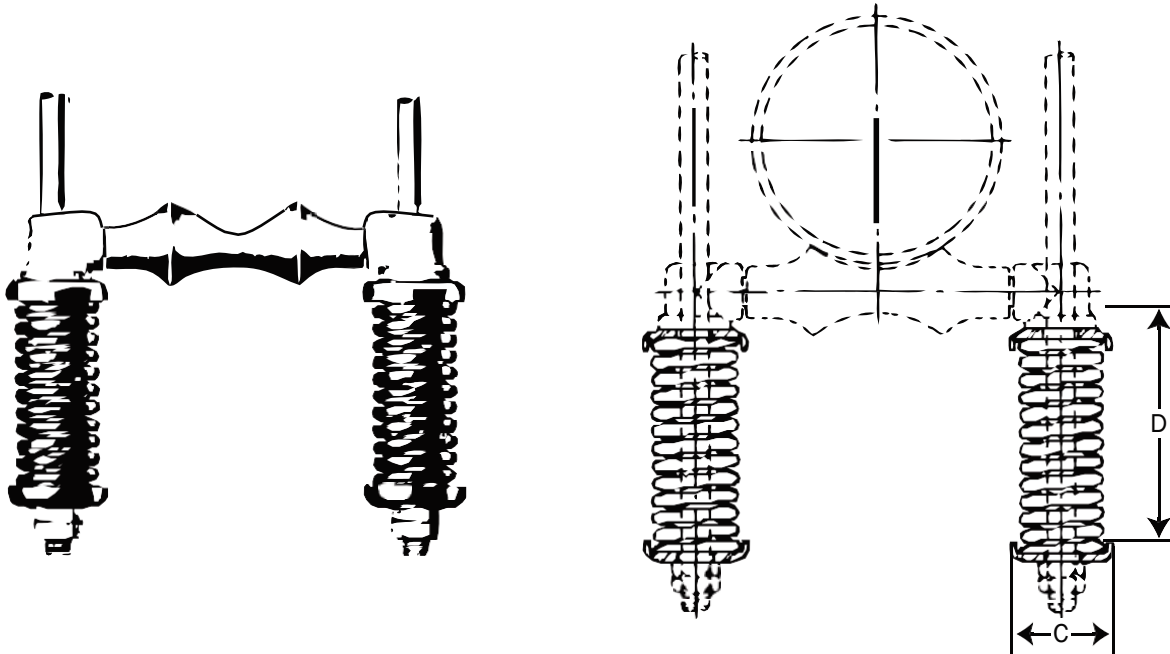

MAXIMUM RECOMMENDED LOAD: 3000 lbs.

MATERIAL: Spring cushion hanger consists of a set of two springs and four retainers only.

SERVICE: Generally used with single pipe roll. Recommended for installation where the vertical movement does not exceed 1 1/4 inches.

APPROVALS: Complies with Federal Specification WW-H-171E (Type 50) & Manufacturers Standardization Society SP-69 (Type 49).

All Dimensions in inches

Spring Number	Max. Recom. Deflection	Load, lb at Max. Recom. Deflection	Deflection Rate of Hanger lb/inch	Weight (approx.) lb. ea.	<b>C</b>	<b>D</b>	Size of Retainer Core	For Road Size	Max. Rod Size
1	1 1/4	535	428	4.5	2 21/32	6 7/16	7/16	3/8	3/4
2	1 1/4	1500	1200	14.0	4 1/8	6 1/16	9/16	1/2	3/4
3	1 1/4	3000	2400	22.0	4 1/8	9 1/16	15/16	7/8	1 1/2