

ROLLER CHAIR

6B

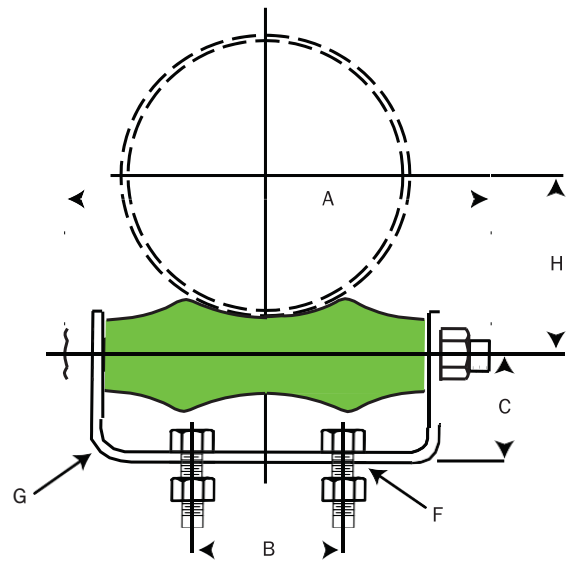
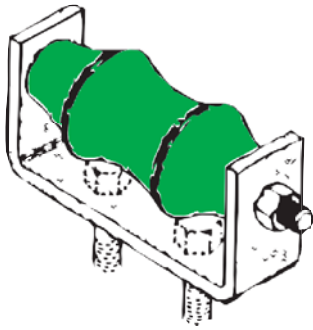

ROLLER CHAIR INCLUDES:

- 1 STEEL BASE
- 1 ROLL AXLE & NUTS
- 2 BOLTS & NUTS
- 1 CAST IRON ROLL (OMIT WHEN ORDERING NON-CONDUCTIVE ROLLER)

SPECIFICATIONS MAY VARY - All Dimensions in inches

Pipe Size	Wt. lbs/ea.	A	*B	C	Bolt Size F	Steel Size G	H	Max. Load lbs.	Axle Size
2	1.1	4	1 1/4	1 1/2	3/8 x 1 1/2	1/4 x 1 1/4	1 5/8	300	3/8
3	1.6	5 3/8	2	1 3/4	3/8 x 1 1/2	1/4 x 1 1/4	2 1/4	600	1/2
4	2.9	6 5/8	2	2 5/16	1/2 x 1 1/2	3/8 x 1 1/2	2 13/16	700	1/2
5	3.9	7 7/8	3	2 1/2	1/2 x 1 1/2	3/8 x 1 1/2	3 7/16	700	5/8
6	6.0	9 1/4	3 1/8	2 3/4	1/2 x 1 1/2	3/8 x 2	4	1000	3/4
8	9.0	11 5/8	4	3	5/8 x 1 1/2	3/8 x 2	5 1/8	1300	7/8
10	13.8	14 1/8	5 1/4	3 5/8	5/8 x 2	1/2 x 2	6 3/8	1700	7/8
12	18.9	16 1/8	5 1/2	4 1/8	5/8 x 2	1/2 x 2	7 7/16	2300	1
14	28.07	18 3/4	6 1/2	4 11/16	3/4 x 2	1/2 x 2 1/2	8 3/8	3100	1 1/8
16	34.93	21	8 1/4	5 3/8	3/4 x 2 1/2	1/2 x 3	9 3/8	3900	1 1/4
18	44.35	23 1/8	9 1/4	6	3/4 x 2 1/2	1/2 x 3	10 7/16	4200	1 1/4
20	56.34	24 5/8	10 1/4	6 1/2	3/4 x 2 1/2	1/2 x 3	11 5/8	4500	1 1/4
24	87.52	29 3/8	12 1/4	7 7/8	7/8 x 3 1/2	5/8 x 4	14	6000	1 1/2

*Axle lengths may affect B dimension. Contact supplier before pre drilling holes.