

Operating Instructions

Böhmer Fully Welded Ball Valves - *Type BBF*

Authorized Distributor:

Liberty Sales and Distribution, LLC

2880 Bergey Road, Suite F

Hatfield, PA 19440

Phone: (877) 373-0118

Fax: (888) 850-3787

Email: sales@libertysales.net

Rev.: 06/2013

TABLE OF CONTENTS	PAGE
1. Safety instructions	3
1.1 Use in accordance with the intended purpose	3
1.2 Action in the case of malfunctions	4
2. Acceptance and transport	5
2.1 State as delivered	5
2.2 Checking of the delivery	5
2.3 Storage	5
2.4 Transport	5
3. Fitting and commissioning	6
3.1 Mounting position	6
3.2 Welding	7
3.3 Water pressure test	7
4. Operating and test for tightness	9
4.1 Opening and shutting off	9
4.2 Proof of tightness under operating conditions	9
4.2.1 Ball valves without test connection	9
4.2.2 Ball valves with test connection	9
5. Maintenance / repairs	11
5.1 Leaks on the actuation journals	11
5.1.1 Ball valves without test connection	11
5.1.2 Ball valves with test connection	12
5.2 Variants	13
• Variant 1	13
• Variant 2	14
• Variant 3	15
6. Accessories	16
6.1 Injecting of sealing agent	16

1. SAFETY INSTRUCTIONS

1.1 Use in accordance with the intended purpose

The fully welded type BBF ball valve is designed exclusively for opening pipes fully for the flow of materials or for shutting them completely. Every other form of use, e.g. for regulating flows, counts as not being in accordance with the intended purpose.

Use in accordance with the intended purpose also includes the observation of the instructions in these operating instructions, the maintaining of the operating conditions as stated on the type plate, acceptance certificates and drawings as well as the observation of the relevant accident prevention and environmental protection regulations applying at the place of use.

These operating instructions are intended for the expert personnel of the operator of the ball valve.

The safety instructions are to be read before the ball valve is transported, fitted or repaired and are to be kept safely.

In these operating instructions the safety instructions are high-lighted clearly from the remaining text. There are two different types of safety instruction:

IMPORTANT



Signifies a situation that could be dangerous and gives hints on how damage can be avoided.

DANGER



Indicates the direct risk of danger for health and life and limb or the risk of serious material damage, in each case in the event of the instructions not being observed.

1.2 Action in the case of malfunctions

The following safety instructions are to be observed.

Repairs to the ball valve, which become necessary in the course of the normal operation of the ball valve, may be carried out but only after the permission thereto has been obtained from Böhmer GmbH for each individual case.

All other repairs, e.g. that become necessary following damage through force majeure or through causes which do not lie in the field of normal operation of the ball valve, are to be carried out solely by Böhmer GmbH.

In the case of repairs to be carried out by the ball valve operator's, the following manufacturer's instructions are to be observed:

- The statement of position of Böhmer GmbH is to be obtained before the repair is carried out.
- Photos are to be taken before and after each repair.
- Repairs are to be carried out only using spare parts from and in accordance with the fitting instructions of Böhmer GmbH.
- A report is to be prepared with the following statements:
 - Cause of damage, effect of damage
 - Spare parts, special tools and fitting devices used
 - Repair measures and tests carried out
 - Names of the persons carrying out the repairs, of the person responsible therefor and the date on which the repairs were carried out
 - Photos

2. ACCEPTANCE AND TRANSPORT

2.1 State as delivered

The ball valves are provided with a coating and type plate in accordance with the particular order and - in so far as the order does not contain something different - are supplied in the following form:

- The ends on to which welding is to be carried out and the flange connection sides are provided with an anti-corrosion agent.
- Connection openings are closed with PE protective caps or wood lids to prevent dirt and moisture getting in.
- The ball valves are packed on wooden pallets or in skeleton containers.

2.2 Checking of the delivery

Check the delivery without delay following receipt for transport damage. In the case of damage observe the instructions of the insurance companies which - amongst other things - will prescribe an immediate recording of the state of affairs by the forwarding agent. Wherever possible document damage with photos.

In addition check the delivery for completeness against the delivery notes. Inform Böhmer GmbH without delay if anything is missing.

2.3 Storage

- Leave the ball valves in the transport devices and in the packing material.
- Protect the ball valves against dirt if necessary. Cover them with plastic film. Ball valves have to be stored in dry conditions and under cover.
- Do not actuate the ball valves while they are being stored.

2.4 Transport

IMPORTANT



Transport each ball valve in such a way that you do not damage it thereby. If using chains for lifting, place something suitable between the ball valve and the chain to prevent damage to the external paintwork. The paintwork has a protective function. Accordingly you must not allow it to be damaged at any point.

DANGER



**If the ball valve is delivered with the drive mounted on it, do not secure the lifting devices (ropes, chains etc.) to the drive but only to the ball valve itself. DANGER TO LIFE AND LIMB!
Secure the load in such a way that it cannot tip over to the side. DANGER TO LIFE AND LIMB!**

3. FITTING AND COMMISSIONING

3.1 Mounting position

The ball valves are supplied in the open position. Fit them into the line in this state.

IMPORTANT



Do not put the ball valves into circuit until the pipes have been cleaned since otherwise the balls and seating rings will be unnecessarily subjected to or even damaged by dirt, rust and assembly residues.

In its standard version, the ball valve is designed for fitting in lines of pipes running horizontally. In this situation the actuation shaft is aligned vertically upwards. Other modes of fitting (e.g. pipe vertical, actuation shaft horizontal) are possible when this is specified in the order.

The type BBF fully welded ball valves in sizes up to DN 100 (4") can be fitted in all fitting positions without approval having to be obtained therefor from Böhmer GmbH.

IMPORTANT



Consult Böhmer GmbH when planning a different fitting position for the ball valves of sizes in excess of DN 100.

If it is necessary for the weight of the ball valve to be supported, the ball valve must be provided with and stand on its own foundation or be supported separately in another way whereby in each case it must be free to slide in its axial direction. Do not use the ball valve as a fixing point for the line of pipes but support these separately.

IMPORTANT



In the case of ball valves with a test connection, the inside of the housing should be drained prior to commissioning prior to the periods in which frost can be expected.

IMPORTANT



Before subjecting a ball valve to pressure, check that the test connection is in the fully closed position if one is fitted.

3.2 Welding

Depending on what is ordered, each ball valve has either two flange ends, one flange end and one welding-on end, or two welding-on ends.

The welding-on ends and the flange connection sides of the ball valve are protected with an anti-corrosion agent when supplied. Accordingly you must remove this before welding on the welding-on end or connecting the flange.

IMPORTANT



Do not remove the protective caps until the ball valve is at the location at which it is to be used and then only immediately before it is to be fitted!

The ball valve is to be fitted in its 100 % open position and should first of all **NOT** be actuated. When welding the ball valve on, take care that the seals inside the ball valve will not be heated to a temperature in excess of the permitted level of 140 °C. In this connection the distances to the welding seam stated in the following table hold good (if necessary the region between the welding seam and the seals must be properly cooled).

Nominal width	Distance to welding seam
1" - 3"	50 mm
4" - 8"	70 mm
10" - 16"	90 mm
> 16"	150 mm

The above also holds good for all preheating work carried out as a preparatory stage for welding.

3.3 Water pressure test

Only clean water of drinking water quality may be used as the pressure medium. Carry out the measures in the sequence given below:

Prior to carrying out the water pressure test, clean the line of pipes and the ball valves in order to completely remove all dirt, rust and assembly residues.

After filling the pipe with water, move the ball to the closed position and then open it again a little (10-20 degrees). In this way you equalize the pressure on the sealing rings and ball and protect these in this way from being overloaded by the test pressure which will be well in excess of the nominal pressure.



IMPORTANT

The test pressure may not be more than 1.5 times the nominal pressure or, as the case may be, 1.5 times the permitted operating pressure.

Carry out the water pressure test.

After the water pressure test, move the ball to the fully open position again (or where necessary to the fully closed position) and drain the line.

If there is a test connection on the ball valve, drain the inside of the housing of the ball valve via this connection.

Actuate the ball valve once or twice with the test connection open. Then close the test connection again.

If there is not a test connection, the ball valve should be actuated once or twice.

4. OPERATING AND TEST FOR TIGHTNESS

4.1 Opening and shutting off

The open or closed position of the ball valve is defined by turning the actuation shaft by 90 ° to its limit position, i.e. so that the delivery flow has the full cross-sectional area open to it or so that the flow is completely shut off.

Note:

To ensure that the ball valve will have a long service life, pay attention to the fact that the ball must always be moved to the fully OPEN or the fully CLOSED position and is never left in an intermediate position in the operating mode.

Lines for measuring and monitoring purposes can be connected to the test connection if there is one.

IMPORTANT



Keep to the operating conditions stated on the type plate.

4.2 Proof of tightness under operating conditions

Differentiation is made here between the following forms of execution:

4.2.1 Ball valves without test connection

With this form of execution a leakage test can only be carried out downstream of the closed ball valve.

4.2.2 Ball valves with test connection

With this form of execution a leakage test can be carried out via the test connection.

IMPORTANT



The test pressure may not be more than 1.1 times the nominal pressure or, as the case may be, 1.1 times the permitted operating pressure.

A tightness test must be carried out with the ball valve in its closed position. If this has been agreed in the order, the tightness can also be checked when the ball valve is open.

Open the test connection slowly to depressurize the inside of the housing - but do this only when the ball is in its closed position. (If this has been agreed in the order, the test can also be carried out when the ball valve is in its open position.) Danger of injury!

The general safety regulations applying at the place of installation are to be observed in respect of the medium escaping into the atmosphere.

DANGER

There can be a DANGER TO LIFE depending on the medium!



Wait until the complete system has been depressurized and that no more medium is escaping. After allowing a period for equilibrium to be reached, a check is then made to see whether further medium is escaping. If there is, then the amount can be measured by counting the number of drops or bubbles per minute.

If there is a leak at the spindle passage seal, then this can often be eliminated by opening and closing the ball valve several times.



Then close the test connection again!

Option: Injecting in of sealing agent

When a system for injecting in sealing agent has been agreed in the order and if the level of leakage cannot be accepted, a suitable sealing agent can be forced in via the injection nipples until the leakage stops. An analogous procedure can be carried out with the actuation journals (see Fig. 1).

For a description and the mode of procedure see section 6.

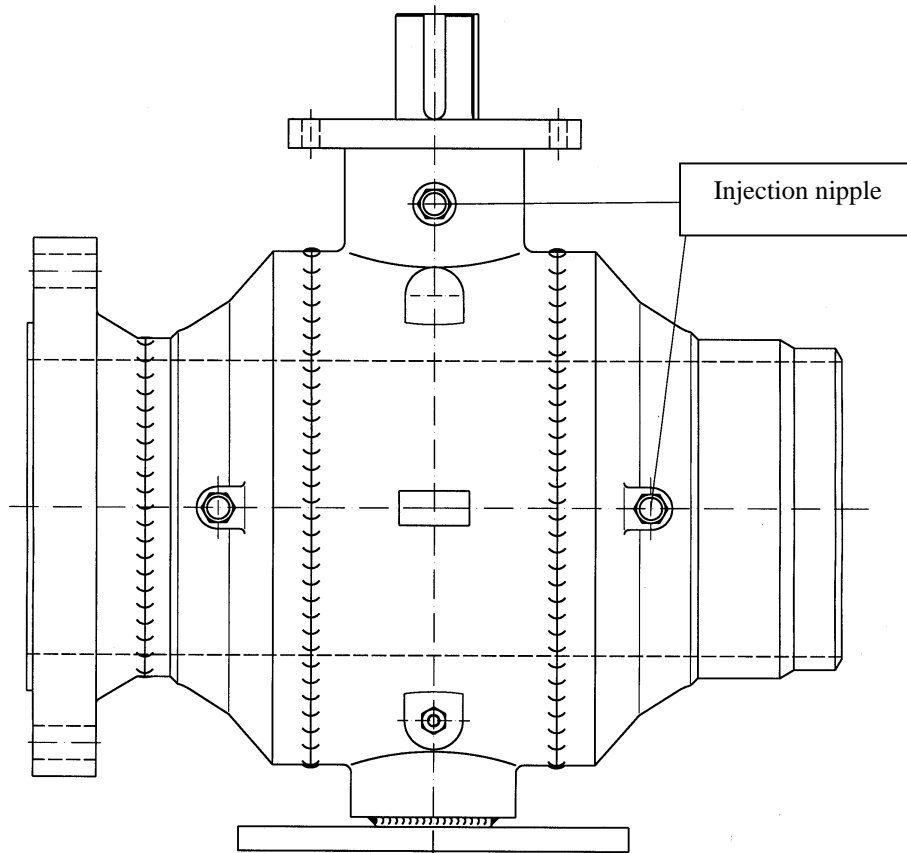

Fig. 1

5. MAINTENANCE / REPAIRS

Maintenance and repairs are only to be carried out on ball valves with nominal widths in excess of DN 50 (2"). Böhmer GmbH is to be consulted in special cases.

IMPORTANT



You may only carry out repairs to the ball valve when you have received special training from Böhmer GmbH in how to carry out these and when permission to carry out the particular repair has been obtained from Böhmer GmbH for each individual case.

All other repairs, e.g. in the case of damage through force majeure or through causes which do not lie in the field of normal operation of the ball valve, are to be carried out solely by Böhmer GmbH.

The ball valve is a fitting that requires no maintenance. The bearings on the actuation journals and bearing pins (when present) are low-wearing, self-lubricating PTFE products with excellent sliding properties. This fact means that the actuating torque remains at a low and almost constant level even after a long period of operation regardless of how often the ball valve is switched.

We recommend that each ball valve be put through at least one actuation cycle a year in order to check that it is functioning reliably.

The repairs, which Böhmer GmbH permit the operator to carry out, can be executed with the housing remaining in the line of pipes.

You may only carry out any repair during the warranty period after having obtained the approval of Böhmer GmbH since otherwise the warranty obligation will be voided.

5.1 Leaks on the actuation journals

Differentiation is made between two basic types of fully welded ball valves:

5.1.1 Ball valves without test connection:

DANGER:



When there is a leak at the actuation journal with this form of execution, the connected line of pipes must be depressurized before dismantling is commenced. Otherwise it will be possible for the medium to escape in an uncontrolled manner during dismantling causing injury and/or material damage.

The dismantling steps for changing the actuation shaft seal are described under Para. 5.2.

5.1.2 Ball valves with test connection:

- When there is a leak with this form of execution, the inside of the housing of the ball valve can be depressurized when the valve is in its closed position without the connected line of pipes having to be depressurized. The inside of the housing can also be depressurized when the ball valve is in its open position when this has been agreed in the order.

DANGER:



With this form of execution, the inside of the housing must be depressurized before dismantling is commenced. Otherwise it will be possible for the medium to escape in an uncontrolled manner during dismantling causing injury and/or material damage.

To carry out this depressurization, the shutting-off agent (ball) must be in its closed position (also in the open position depending on the order and the particular form of execution) and the inside of the housing must have been depressurized via the test connection and rendered absolutely free of pressure. The test connection must remain fully open until all assembly work has been completed.

Close the test connection again after all repair work has been completed!

The dismantling steps for changing the actuation shaft seal are described under Para. 5.2.

5.2 Variants

There are three different forms of execution of the spindle passage.

Variant 1

Medium is prevented from escaping through the spindle passage by two sealing elements (see Fig. 2, Fig. 3).

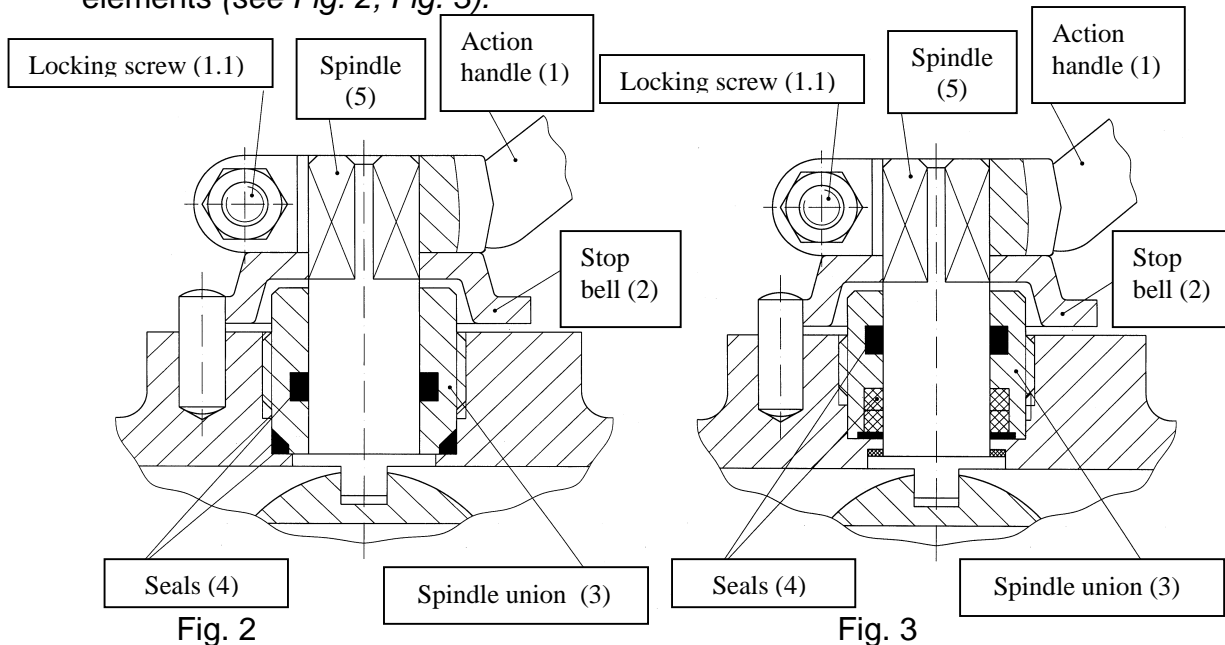

The first measure to eliminate a leak at the spindle is to tighten up the spindle union (3). If this does not cure the leak satisfactorily, the seals must be replaced.



IMPORTANT:

**The further steps may only be carried out after it has been reliably ascertained that the ball valve has been depressurized!
DANGER TO LIFE if the medium escapes!**

Note: The work steps must be carried out precisely in the order given below.

1. Remove the actuation handle (1) by releasing locking screw (1.1); when a drive is connected, mark the position and then disconnect the drive.
2. Remove the stop bell (2); this step does not arise if there is a drive.
3. Unscrew the spindle union (3).
4. Replace the seals (4).
5. Replace the spindle union (3).
6. Replace the stop bell (2) and the actuation handle (1) or, as the case may be, drive.
7. Tighten up the locking screw (1.1); this step does not arise if there is a drive.

Variant 2

Medium is prevented from escaping through the spindle passage by four seals (three O-rings and one flat seal). These seals can be replaced (see Fig. 4).

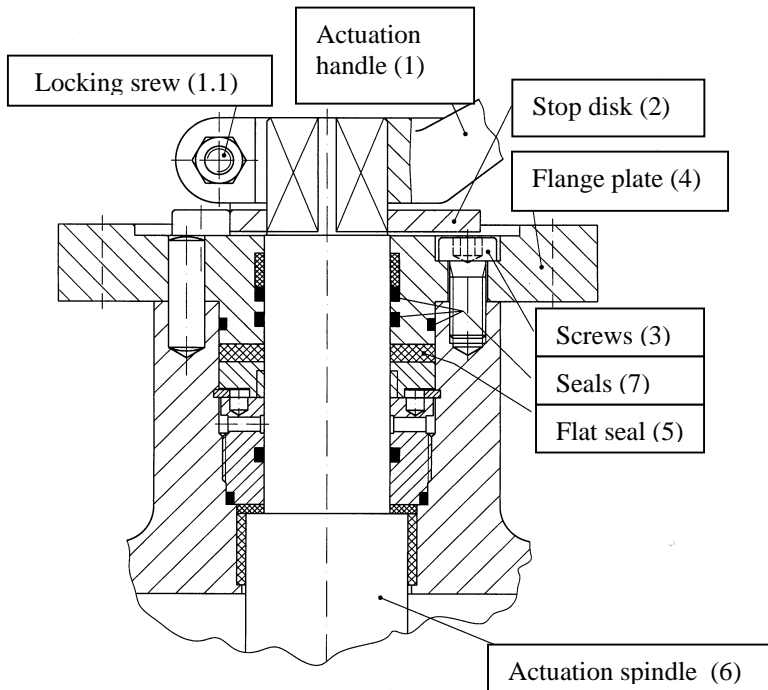

Fig. 4

Option: Injection of sealing agent

If the ball valve has a sealing agent connection, the first measure that can be taken to eliminate the leak is to force in a suitable sealing agent. The sealing agent fills up every hollow space and stops the leak.

For a description and mode of procedure for this see section 6.

Should this measure not bring about a satisfactory result in the long-term, the seals must be replaced.

IMPORTANT:



The further steps may only be carried out after it has been reliably ascertained that the ball valve has been depressurized!

DANGER TO LIFE if the medium escapes!

Note: The work steps must be carried out precisely in the order given below.

1. Remove the actuation handle (1) by releasing locking screw (1.1); when a drive is connected, mark the position and then disconnect the drive.
2. Remove the stop disk (2); this step does not arise if there is a drive.
3. The flange plate (4) can be removed after the screws (3) have been removed.
4. Remove the flat seal (5).
5. The actuation spindle (6) cannot be removed since with this variant it is secured against being "blown out".

6. Replace the seals (7) in the flange plate (4).
7. Fit a new flat seal (5).
8. Fit the flange plate (4), tightening up the screws (3) "crosswise".
9. Replace the stop disk (2) and the actuation handle (1) or, as the case may be, drive.
10. Tighten up the locking screw (1.1); this step does not arise if there is a drive.

Variant 3

Here medium is prevented from escaping by two seals (1) (see Fig. 5).

With this version no adjustments can be carried out and the seals (1) cannot be replaced. If leakage, occurs, the ball valve must be removed from the line of pipes.

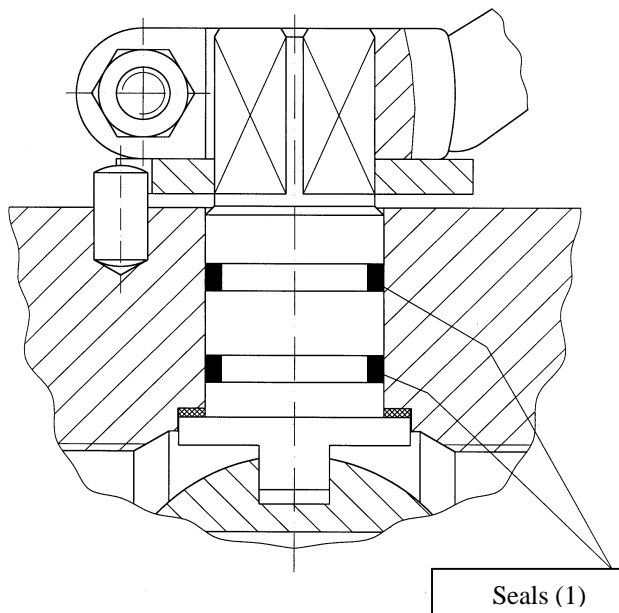

Fig. 5

6. ACCESSORIES

6.1 Injecting of sealing agent into the journal seal / seating rings

The transportable and easy-to-use sealing agent gun generates pressures of up to 100 Mpa. The sealing agent used is a highly viscous paste.

When it is necessary to inject sealing agent, a sealing agent cartridge is inserted in the gun, the cap is removed from the injection nipple and the connection piece of the gun is pushed over the injection nipple (see Fig. 6).

The sealing agent can now be forced into the ball valve by actuating the lever of the gun.

When the pressure gauge on the gun shows an increase in pressure, this indicates that the sealing agent channels in the ball valve are full.

Recommended sealing agent in so far as there are no particular prescriptions:
VAL-TEX No. 80, multi-purpose agent based on hydrocarbons, temperature range - 29°C to + 260°C.

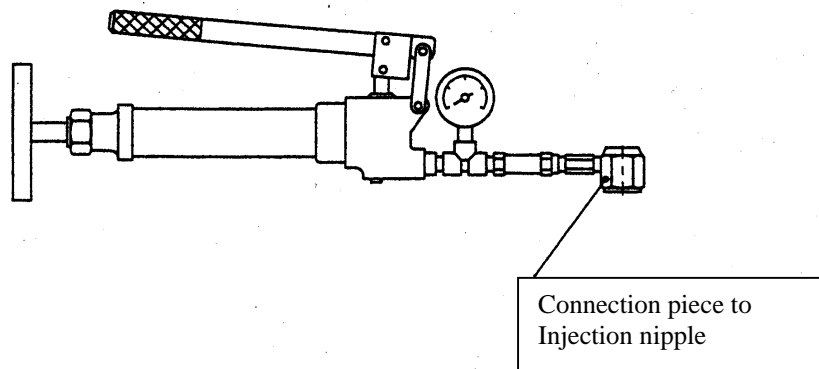

Fig. 6

Authorized Distributor:

Liberty Sales and Distribution, LLC

2880 Bergey Road, Suite F

Hatfield, PA 19440

Phone: (877) 373-0118

Fax: (888) 850-3787

Email: sales@libertysales.net