

**ERITECH®**

# Cathodic Protection Connections

Featuring CADWELD® Molds  
Weld Metal and Accessories



Facility Electrical Protection

DISTRIBUTOR:

**Liberty Sales and Distribution, LLC**

2880 Bergey Road, Suite F

Hatfield, PA 19440

Phone: (877) 373-0118

Fax: (888) 850-3787

Email: [sales@libertysales.net](mailto:sales@libertysales.net)

**ERICO®**

# Introduction/Table of Contents

## The CADWELD Process

CADWELD connections are the accepted method of attaching Cathodic Protection leads to pipes (steel or cast iron), tanks and structures.

CADWELD connections weld the conductors and the structure to be protected so no galvanic corrosion can occur at the interface. The CADWELD process is specifically formulated to provide minimum heat effect on steel, which is especially important on thin-wall, high-stress pipes.

CADWELD connections are also used for header cable taps, conductor splices and terminations, and ground rod connections.

## ERICO® Facts

A CADWELD Connection . . .

- Has current carrying capacity equal to that of the conductor.
- Is permanent with a low resistance connection that cannot loosen or corrode.
- Uses lightweight, inexpensive equipment.
- Requires no external source of power or heat.
- Requires no special skills.
- Can be easily checked for quality.

ERICO is the pioneer of the CADWELD Exothermic Welding Process for permanent Cathodic Protection connections. Specifying the CADWELD Process in your construction plans will dramatically extend the lifespan of infrastructure systems.

CADWELD connections are made with a semi-permanent graphite mold, which holds the conductors to be welded. Weld metal (a mixture of copper oxide and aluminum) is dumped into the top of the mold. The mold is covered and the weld metal ignited. The exothermic reaction produces molten copper, which results in a permanent, high conductivity connection.

## TABLE OF CONTENTS

INTRODUCTION	
<b>Connections to Steel</b>	Page
CAHA Type	1
CAHC Type	2
CAVS Type	3
<b>Connections to Cast Iron</b>	
CAHB Type	4
CAHE Type	4
CAVH Type	4
<b>Connections to Ground Rod</b>	
Type CAGR	5
Type CAGT	5
<b>Connections of Cable to Cable</b>	
Type CAPC	6
Type CASS	6
Type CATA	7
<b>Connections of Cable to Lug</b>	
Type CALA	7
<b>Bonds</b>	
Plain Strap Bonds	8
Punched Strap Bonds	9
Formed Terminal - Factory & Field Made	10
Formed Terminal - with Pigtail	11
<b>Welders and Molds</b>	12
<b>Weld Metal</b>	12
<b>Tools and Materials</b>	13 - 15
<b>Technical Information</b>	
PIPING CODE	16
PIPE WALL THICKNESS	17
Ductile Iron	17
<b>Cross Reference</b>	18

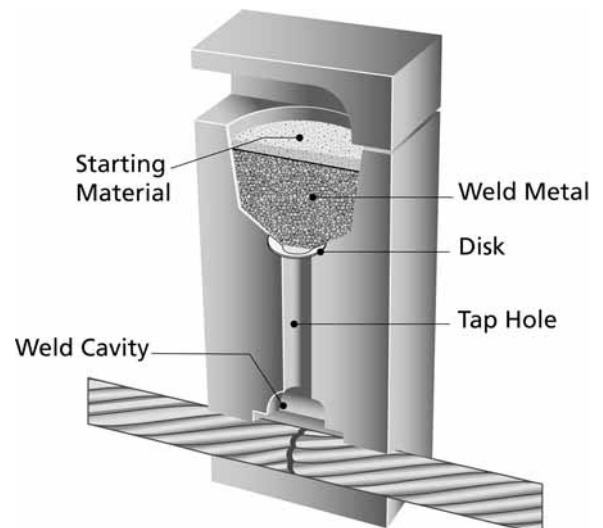

Tap conductor to top of horizontal STEEL pipe or flat surface.  
 Note: For DUCTILE IRON, see page 17.

Conductor Size	Surface	Welder Part No.†	Welder Price	Weld Metal
#14 to #10 Solid (use sleeve CAB-133-1H)* or #8 Solid or Stranded, or #6 Solid	Flat (4" & larger pipe)	CAHAA-1G	CAA	CA15
	3/4" to 3-1/2" pipe	CAHAA-1GA	CAA	CA15
6 Stranded	Flat (4" & larger pipe)	CAHAA-1H	CAA	CA15
	3/4" to 3-1/2" pipe	CAHAA-1HA	CAA	CA15
4 Solid	Flat (6" & larger pipe)	CAHAA-1K	CAA	CA15
	3/4" to 3-1/2" pipe	CAHAA-1KA	CAA	CA15
	4" to 5" pipe	CAHAA-1KB	CAA	CA15
4 Stranded	Flat (6" & larger pipe)	CAHAA-1L	CAA	CA15
	3/4" to 3-1/2" pipe	CAHAA-1LA	CAA	CA15
	4" to 5" pipe	CAHAA-1LB	CAA	CA15
2 Solid	Flat (10" & larger pipe)	CAHAA-1T	CAA	CA25
	1" to 3-1/2" pipe	CAHAA-1TA	CAA	CA25
	4" to 8" pipe	CAHAA-1TB	CAA	CA25
2 Stranded	Flat (16" & larger pipe)	CAHAA-1V	CAA	CA32
	1" to 3-1/2" pipe	CAHAA-1VA	CAA	CA32
	4" to 8" pipe	CAHAA-1VB	CAA	CA32
	10" to 14" pipe	CAHAA-1VC	CAA	CA32
1 Stranded	Flat (16" & larger pipe)	CAHAA-1Y	CAA	CA45
	1-1/2" to 3-1/2" pipe	CAHAA-1YA	CAA	CA45
	4" to 8" pipe	CAHAA-1YB	CAA	CA45
	10" to 14" pipe	CAHAA-1YC	CAA	CA45
1/0 Stranded	Flat (20" & larger pipe)	CAHAA-2C	CAA	CA65
	2-1/2" to 3-1/2" pipe	CAHAA-2CA	CAA	CA65
	4" to 8" pipe	CAHAA-2CB	CAA	CA65
	10" to 18" pipe	CAHAA-2CC	CAA	CA65
2/0 Stranded	Flat (20" & larger pipe)	CAHAA-2G	CAA	CA65
	2-1/2" to 3-1/2" pipe	CAHAA-2GA	CAA	CA65
	4" to 8" pipe	CAHAA-2GB	CAA	CA65
	10" to 18" pipe	CAHAA-2GC	CAA	CA65

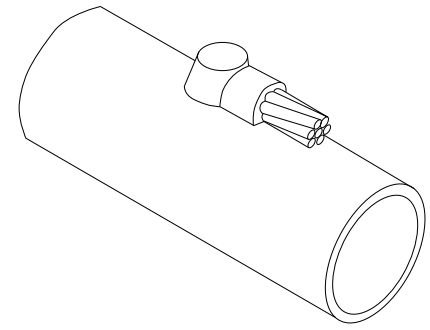

CAHA - Cable to Horizontal Steel Pipe

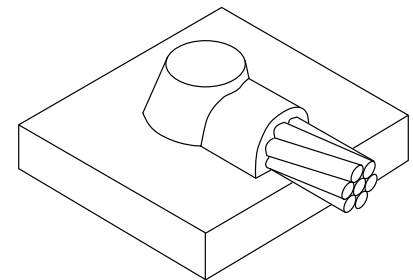

CAHA - Cable on surface

\*1 sleeve per connection.

† Welder Part No. includes mold frame. If mold only (less frame) is required, order - Welder Part No. - "M".

Through conductor to top of horizontal STEEL pipe or flat surface.

NOTE: For DUCTILE IRON, see page 17.

Conductor Size	Surface	Welder Part No. <sup>†</sup>	Welder Price	Weld Metal
#14 to #10 Solid (use sleeve CAB-133-1H)* or #8 Solid or Stranded, or #6 Solid	Flat (12" & larger pipe)	CAHCA-1G	CAA	CA25
	3/4" to 2" pipe	CAHCA-1GA	CAA	CA25
	2-1/2" to 5" pipe	CAHCA-1GB	CAA	CA25
	6" to 10" pipe	CAHCA-1GC	CAA	CA25
6 Stranded	Flat (12" & larger pipe)	CAHCA-1H	CAA	CA25
	3/4" to 2" pipe	CAHCA-1HA	CAA	CA25
	2-1/2" to 5" pipe	CAHCA-1HB	CAA	CA25
	6" to 10" pipe	CAHCA-1HC	CAA	CA25
4 Solid	Flat (12" & larger pipe)	CAHCA-1K	CAA	CA25
	3/4" to 2" pipe	CAHCA-1KA	CAA	CA25
	2-1/2" to 5" pipe	CAHCA-1KB	CAA	CA25
	6" to 10" pipe	CAHCA-1KC	CAA	CA25
4 Stranded	Flat (12" & larger pipe)	CAHCA-1L	CAA	CA25
	3/4" to 2" pipe	CAHCA-1LA	CAA	CA25
	2-1/2" to 5" pipe	CAHCA-1LB	CAA	CA25
	6" to 10" pipe	CAHCA-1LC	CAA	CA25
2 Solid	Flat (14" & larger pipe)	CAHCA-1T	CAA	CA32
	2" to 3-1/2" pipe	CAHCA-1TA	CAA	CA32
	4" to 6" pipe	CAHCA-1TB	CAA	CA32
	8" to 10" pipe	CAHCA-1TC	CAA	CA32
2 Stranded	Flat (18" & larger pipe)	CAHCA-1V	CAA	CA45
	2" to 3-1/2" pipe	CAHCA-1VA	CAA	CA45
	4" to 8" pipe	CAHCA-1VB	CAA	CA45
	10" to 16" pipe	CAHCA-1VC	CAA	CA45
1 Stranded	Flat (18" & larger pipe)	CAHCA-1Y	CAA	CA45
	2" to 3-1/2" pipe	CAHCA-1YA	CAA	CA45
	4" to 8" pipe	CAHCA-1YB	CAA	CA45
	10" to 16" pipe	CAHCA-1YC	CAA	CA45
1/0 Stranded	Flat (30" & larger pipe)	CAHCA-2C	CAA	CA65
	3" to 4" pipe	CAHCA-2CA	CAA	CA65
	5" to 6" pipe	CAHCA-2CB	CAA	CA65
	8" to 10" pipe	CAHCA-2CC	CAA	CA65
	12" to 28" pipe	CAHCA-2CD	CAA	CA65
2/0 Stranded	Flat (30" & larger pipe)	CAHCA-2G	CAA	CA65
	3" to 4" pipe	CAHCA-2GA	CAA	CA65
	5" to 6" pipe	CAHCA-2GB	CAA	CA65
	8" to 10" pipe	CAHCA-2GC	CAA	CA65
	12" to 28" pipe	CAHCA-2GD	CAA	CA65

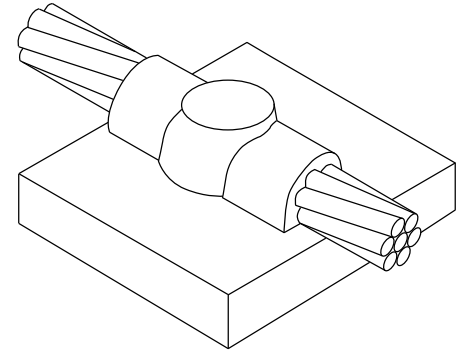

CAHC – Cable on surface

\* 2 sleeves per connection.

† Welder Part No. includes mold frame. If mold only (less frame) is required, order - Welder Part No. - "M".

Tap conductor to vertical STEEL pipe or flat surface.

NOTE: For DUCTILE IRON, see page 17.

Conductor Size	Surface	Welder Part No.†	Welder Price	Weld Metal
#14 to #10 Solid (use sleeve CAB-133-1H)* or #8 Solid or Stranded, or #6 Solid	Flat (12" & larger pipe)	CAVST-1G	CAT	CA15
	3/4" to 3-1/2" pipe	CAVST-1GA	CAT	CA15
	4" to 10" pipe	CAVST-1GB	CAT	CA15
6 Stranded	Flat (12" & larger pipe)	CAVST-1H	CAT	CA15
	3/4" to 3-1/2" pipe	CAVST-1HA	CAT	CA15
	4" to 10" pipe	CAVST-1HB	CAT	CA15
4 Solid	Flat (12" & larger pipe)	CAVST-1K	CAT	CA25
	3/4" to 1-1/2" pipe	CAVST-1KA	CAT	CA25
	2" to 4" pipe	CAVST-1KB	CAT	CA25
	5" to 10" pipe	CAVST-1KC	CAT	CA25
4 Stranded	Flat (12" & larger pipe)	CAVST-1L	CAT	CA25
	3/4" to 1-1/2" pipe	CAVST-1LA	CAT	CA25
	2" to 4" pipe	CAVST-1LB	CAT	CA25
	5" to 10" pipe	CAVST-1LC	CAT	CA25
2 Solid	Flat (14" & larger pipe)	CAVST-1T	CAT	CA25
	1" to 1-1/2" pipe	CAVST-1TA	CAT	CA25
	2" to 4" pipe	CAVST-1TB	CAT	CA25
	5" to 12" pipe	CAVST-1TC	CAT	CA25
2 Stranded	Flat (14" & larger pipe)	CAVST-1V	CAT	CA32
	1" to 1-1/2" pipe	CAVST-1VA	CAT	CA32
	2" to 3" pipe	CAVST-1VB	CAT	CA32
	4" to 6" pipe	CAVST-1VC	CAT	CA32
	8" to 12" pipe	CAVST-1VD	CAT	CA32
1 Stranded	Flat (18" & larger pipe)	CAVSP-1Y	CAP	CA45
	1-1/2" to 2-1/2" pipe	CAVSP-1YA	CAP	CA45
	3" to 4" pipe	CAVSP-1YB	CAP	CA45
	5" to 10" pipe	CAVSP-1YC	CAP	CA45
	12" to 16" pipe	CAVSP-1YD	CAP	CA45
1/0 Stranded	Flat (18" & larger pipe)	CAVSP-2C	CAP	CA65
	2-1/2" to 4" pipe	CAVSP-2CA	CAP	CA65
	5" to 10" pipe	CAVSP-2CB	CAP	CA65
	12" to 16" pipe	CAVSP-2CC	CAP	CA65
2/0 Stranded	Flat (18" & larger pipe)	CAVSP-2G	CAP	CA65
	3" to 4" pipe	CAVSP-2GA	CAP	CA65
	5" to 10" pipe	CAVSP-2GB	CAP	CA65
	12" to 16" pipe	CAVSP-2GC	CAP	CA65

\* 1 sleeve per connection.

† Welder Part No. includes mold frame. If mold only (less frame) is required, order - Welder Part No. - "M".

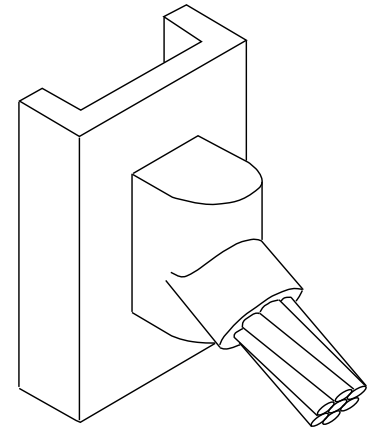

CAVS

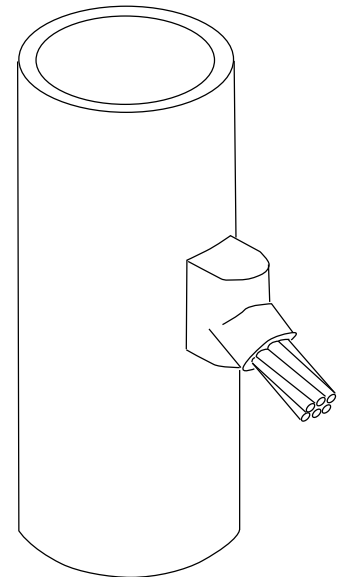

CAVS – Cable on surface

# Connections to Cast Iron

# Type CAHB & CAHE

Type CAHB Tap conductor to top of horizontal CAST IRON pipe or flat surface.

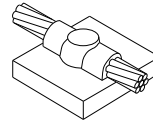
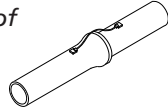

Type CAHE Through conductor to top of horizontal CAST IRON pipe or flat surface.

TYPE CAHB			Conductor Size	Surface	TYPE CAHE		
Welder Part No. †	Welder Price	Weld Metal			Welder Part No. †	Welder Price	Weld Metal
CAHBA-1G	CAA	CA25XF-19	#14 to #10 Solid (use sleeve CAB-133-1H)** or #8 Solid or Stranded, or #6 Solid	Flat (30" & larger pipe) 4" to 24" pipe	CAHEA-1G	CAA	CA32XF-19
CAHBA-1G-P.S.*	CAA	CA25XF-19			CAHEA-1G-P.S.*	CAA	CA32XF-19
CAHBA-1H	CAA	CA25XF-19	6 Stranded	Flat (30" & larger pipe) 4" to 24" pipe	CAHEA-1H	CAA	CA32XF-19
CAHBA-1H-P.S.*	CAA	CA25XF-19			CAHEA-1H-P.S.*	CAA	CA32XF-19
CAHBA-1K	CAA	CA45XF-19	4 Solid	Flat (30" & larger pipe) 4" to 24" pipe	CAHEA-1K	CAA	CA45XF-19
CAHBA-1K-P.S.*	CAA	CA45XF-19			CAHEA-1K-P.S.*	CAA	CA45XF-19
CAHBA-1L	CAA	CA45XF-19	4 Stranded	Flat (30" & larger pipe) 4" to 24" pipe	CAHEA-1L	CAA	CA45XF-19
CAHBA-1L-P.S.*	CAA	CA45XF-19			CAHEA-1L-P.S.*	CAA	CA45XF-19
CAHBA-1T	CAA	CA45XF-19	2 Solid	Flat (30" & larger pipe) 4" to 24" pipe	CAHEA-1T	CAA	CA45XF-19
CAHBA-1T-P.S.*	CAA	CA45XF-19			CAHEA-1T-P.S.*	CAA	CA45XF-19
CAHBA-1V	CAA	CA45XF-19	2 Stranded	Flat (30" & larger pipe) 4" to 24" pipe	CAHEA-1V	CAA	CA45XF-19
CAHBA-1V-P.S.*	CAA	CA45XF-19			CAHEA-1V-P.S.*	CAA	CA45XF-19
CAHBA-1Y	CAA	CA65XF-19	1 Stranded	Flat (30" & larger pipe) 4" to 24" pipe	CAHEA-1Y	CAA	CA65XF-19
CAHBA-1Y-P.S.*	CAA	CA65XF-19			CAHEA-1Y-P.S.*	CAA	CA65XF-19

\* Specify pipe size. Example: For #2 stranded to 6" pipe. (Type CAHB) CAHBA-1V-6, (Type CAHE) CAHEA-1V-6.

\*\* 1 Sleeve per connection for Type CAHB. 2 Sleeves per connection for Type CAHE.

† Welder Part No. includes mold frame. If mold only (less frame) is required, order - Welder Part No. - "M".

Do not use Types CAHB, CAHE, or CAVH on soil pipe (ASTM A74-82)

A test weld should be made on a section of the pipe being used to determine possibility of detrimental metallurgical effects. For DUCTILE IRON, see page 17.

# Connections to Cast Iron

# Type CAVH

Type CAVH Tap conductor to vertical CAST IRON pipe or flat surface.

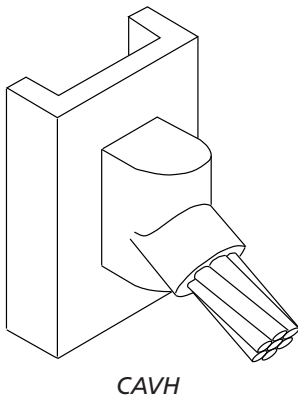

Conductor Size	Surface	Welder Part No. †	Weld Price	Weld Metal
#14 to #10 Solid (use sleeve CAB-133-1H)** or #8 Solid or Stranded, or #6 Solid	Flat (30" & larger pipe) 4" to 24" pipe	CAVHT-1G	CAT	CA25XF-19
		CAVHT-1G-P.S.*	CAT	CA25XF-19
6 Stranded	Flat (30" & larger pipe) 4" to 24" pipe	CAVHT-1H	CAT	CA25XF-19
		CAVHT-1H-P.S.*	CAT	CA25XF-19
4 Solid	Flat (30" & larger pipe) 4" to 24" pipe	CAVHT-1K	CAT	CA32XF-19
		CAVHT-1K-P.S.*	CAT	CA32XF-19
4 Stranded	Flat (30" & larger pipe) 4" to 24" pipe	CAVHT-1L	CAT	CA32XF-19
		CAVHT-1L-P.S.*	CAT	CA32XF-19
2 Solid	Flat (30" & larger pipe) 4" to 24" pipe	CAVHP-1T	CAP	CA45XF-19
		CAVHP-1T-P.S.*	CAP	CA45XF-19
2 Stranded	Flat (30" & larger pipe) 4" to 24" pipe	CAVHP-1V	CAP	CA45XF-19
		CAVHP-1V-P.S.*	CAP	CA45XF-19
1 Stranded	Flat (36" & larger pipe) 4" to 30" pipe	CAVHP-1Y	CAP	CA65XF-19
		CAVHP-1Y-P.S.*	CAP	CA65XF-19

\* Specify pipe size. Example: For #2 stranded to 6" pipe, CAVHP-1V-6.

\*\* 1 sleeve per connection.

† Welder Part No. includes mold frame. If mold only (less frame) is required, order - Welder Part No. - "M".





# Connections to Ground Rods

# Type CAGR & CAGT

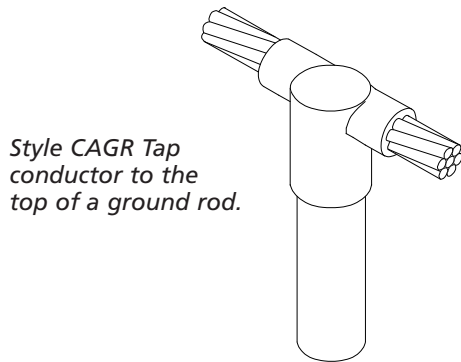

Style CAGR Tap  
conductor to the  
top of a ground rod.

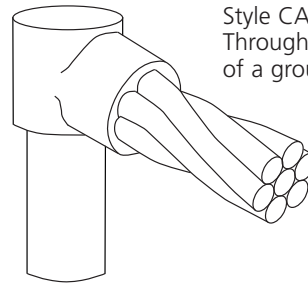

Style CAGT  
Through conductor to the top  
of a ground rod.

Ground Rod Size <sup>1</sup>	Conductor Size	STYLE GR			STYLE GT		
		Welder Part No. <sup>†</sup>	Welder Price	Weld Metal	Welder Part No. <sup>†</sup>	Welder Price	Weld Metal
Nominal 1/2" (Actual .475 Dia.)	#14 to #10 Solid (use sleeve CAB-133-1H)* or #8 Solid or Stranded, or #6 Solid	CAGRT-151G	CAT	CA25	CAGTT-151G	CAT	CA32
	6 Stranded	CAGRT-151H	CAT	CA25	CAGTT-151H	CAT	CA32
	4 Solid	CAGRT-151K	CAT	CA25	CAGTT-151K	CAT	CA32
	4 Stranded	CAGRT-151L	CAT	CA25	CAGTT-151L	CAT	CA32
	2 Solid	CAGRT-151T	CAT	CA32	CAGTP-151T	CAP	CA45
	2 Stranded	CAGRT-151V	CAT	CA32	CAGTP-151V	CAP	CA45
	1 Stranded	CAGRP-151Y	CAP	CA45	CAGTP-151Y	CAP	CA65
	1/0 Stranded	CAGRP-152C	CAP	CA65	CAGTP-152C	CAP	CA65
	2/0 Stranded	CAGRP-152G	CAP	CA65	CAGTP-152G	CAP	CA65
	Nominal 5/8" (Actual .563 Dia.)	#14 to #10 Solid (use sleeve CAB-133-1H)* or #8 Solid or Stranded, or #6 Solid	CAGRT-161G	CAT	CA32	CAGTP-161G	CAP
6 Stranded		CAGRT-161H	CAT	CA32	CAGTP-161H	CAP	CA45
4 Solid		CAGRT-161K	CAT	CA32	CAGTP-161K	CAP	CA65
4 Stranded		CAGRT-161L	CAT	CA32	CAGTP-161L	CAP	CA65
2 Solid		CAGRP-161T	CAP	CA45	CAGTP-161T	CAP	CA65
2 Stranded		CAGRP-161V	CAP	CA45	CAGTP-161V	CAP	CA65
1 Stranded		CAGRP-161Y	CAP	CA45	CAGTP-161Y	CAP	CA65
1/0 Stranded		CAGRP-162C	CAP	CA65	CAGTN-162C	CAN	2-CA45
2/0 Stranded		CAGRP-162G	CAP	CA65	CAGTN-162G	CAN	2-CA45
Nominal 3/4" (Actual .682 Dia.)		#14 to #10 Solid (use sleeve CAB-133-1H)* or #8 Solid or Stranded, or #6 Solid	CAGRT-181G	CAT	CA32	CAGTP-181G	CAP
	6 Stranded	CAGRT-181H	CAT	CA32	CAGTP-181H	CAP	CA45
	4 Solid	CAGRP-181K	CAP	CA45	CAGTP-181K	CAP	CA65
	4 Stranded	CAGRP-181L	CAP	CA45	CAGTP-181L	CAP	CA65
	2 Solid	CAGRP-181T	CAP	CA45	CAGTP-181T	CAP	CA65
	2 Stranded	CAGRP-181V	CAP	CA45	CAGTP-181V	CAP	CA65
	1 Stranded	CAGRP-181Y	CAP	CA45	CAGTP-181Y	CAP	CA65
	1/0 Stranded	CAGRP-182C	CAP	CA65	CAGTN-182C	CAN	2-CA45
	2/0 Stranded	CAGRP-182G	CAP	CA65	CAGTN-182G	CAN	2-CA45

<sup>1</sup> For plain (unthreaded) copper-clad ground rods only. For threaded copper-clad rods or for steel rods, contact ERICO for part number.

<sup>†</sup> Welder Part No. includes mold frame. If mold only (less frame) is required, order - Welder Part No. - "M".

\* 1 sleeve per GR connection. 2 sleeves per GT connection.

# Connections of Cable to Cable

## Type CAPC

Type CAPC  
Tap cable to a through cable.  
Also see Type CATA, page 7

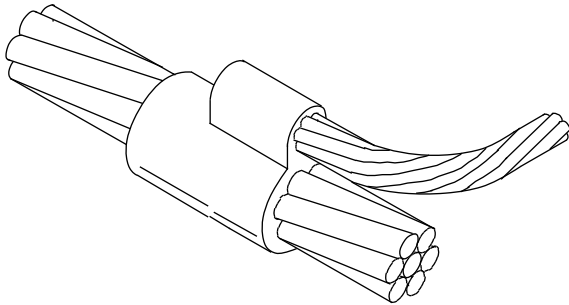

Conductor Size*		Welder Part No.†	Welder Price	Weld Metal
Run	Tap			
6 Stranded	6 Stranded	CAPCT-1H1H	CAT	CA25
	6 Solid	CAPCT-1H1G	CAT	CA25
	8 Stranded	CAPCT-1H1E	CAT	CA25
	8 Solid	CAPCT-1H1D	CAT	CA25
4 Stranded	4 Stranded	CAPCT-1L1L	CAT	CA32
	6 Stranded	CAPCT-1L1H	CAT	CA32
	6 Solid	CAPCT-1L1G	CAT	CA32
	8 Stranded	CAPCT-1L1E	CAT	CA32
	8 Solid	CAPCT-1L1D	CAT	CA32
2 Stranded	2 Stranded	CAPCP-1V1V	CAP	CA65
	4 Stranded	CAPCP-1V1L	CAP	CA45
	6 Stranded	CAPCT-1V1H	CAT	CA32
	6 Solid	CAPCT-1V1G	CAT	CA32
	8 Stranded	CAPCT-1V1E	CAT	CA32
	8 Solid	CAPCT-1V1D	CAT	CA32
1 Stranded	2 Stranded	CAPCP-1Y1V	CAP	CA65
	4 Stranded	CAPCP-1Y1L	CAP	CA45
	6 Stranded	CAPCP-1Y1H	CAP	CA45
	6 Solid	CAPCP-1Y1G	CAP	CA45
	8 Stranded	CAPCP-1Y1E	CAP	CA45
	8 Solid	CAPCP-1Y1D	CAP	CA45
1/0 Stranded	2 Stranded	CAPCP-2C1V	CAP	CA65
	4 Stranded	CAPCP-2C1L	CAP	CA65
	6 Stranded	CAPCP-2C1H	CAP	CA45
	6 Solid	CAPCP-2C1G	CAP	CA45
	8 Stranded	CAPCP-2C1E	CAP	CA45
	8 Solid	CAPCP-2C1D	CAP	CA45
2/0 Stranded	2 Stranded	CAPCN-2G1V	CAN	2-CA45
	4 Stranded	CAPCP-2G1L	CAP	CA65
	6 Stranded	CAPCP-2G1H	CAP	CA65
	6 Solid	CAPCP-2G1G	CAP	CA65
	8 Stranded	CAPCP-2G1E	CAP	CA65
	8 Solid	CAPCP-2G1D	CAP	CA65

\* For #10 Solid through #14 Tap, use sleeve CAB-133-1H on wire in welder for #6 Stranded Tap.

† Welder Part No. includes mold frame. If mold only (less frame) is required, order - Welder Part No. - "M".

# Connections of Cable to Cable

## Type CASS

Type CASS  
Splice of conductors.

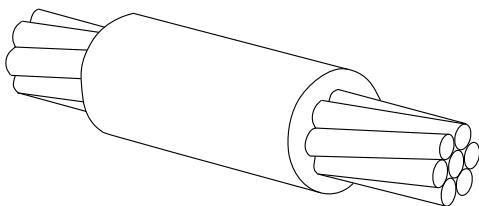

Conductor Size	Welder Part No.†	Welder Price	Weld Metal
12 Solid	CASST-001	CAT	CA15
10 Solid	CASST-1A	CAT	CA15
8 Solid	CASST-1D	CAT	CA15
6 Solid	CASST-1G	CAT	CA25
6 Stranded	CASST-1H	CAT	CA25
4 Solid	CASST-1K	CAT	CA25
4 Stranded	CASST-1L	CAT	CA25
2 Solid	CASST-1T	CAT	CA32
2 Stranded	CASST-1V	CAT	CA32
1 Stranded	CASST-1Y	CAT	CA32
1/0 Stranded	CASSP-2C	CAP	CA45
2/0 Stranded	CASSP-2G	CAP	CA65

† Welder Part No. includes mold frame. If mold only (less frame) is required, order - Welder Part No. - "M".





# Connections of Cable to Cable

## Type CATA

Type CATA connections are available for any combination of run and tap conductor sizes. For small size taps, the Type CAPC is recommended. Contact your local distributor or ERICO for additional information.

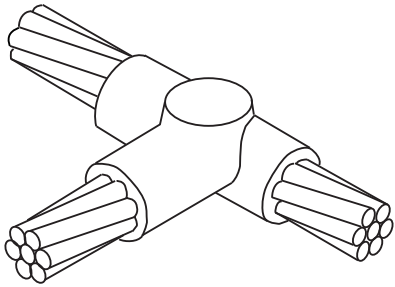

### Concentric Strand Copper Cable

Run	Cable Size Tap	Welder Mold Part No.	Weld Price	Metal
2	2	CATAN-1VIV	CAN	CA45
	4	CATAN-1V1L	CAN	CA45
1	1	CATAN-1Y1Y	CAN	CA45
	2	CATAN-1Y1V	CAN	CA45
	4	CATAN-1Y1L	CAN	CA45
1/0	1	CATAN-2C1Y	CAN	CA45
	2	CATAN-2C1V	CAN	CA45
	4	CATAN-2C1L	CAN	CA45
2/0	1	CATAN-2G1Y	CAN	CA45
	2	CATAN-2G1V	CAN	CA45
	4	CATAN-2G1L	CAN	CA45

# Connections of Cable to Lug

## Type CALA

Type CALA  
Cable terminals (Lugs).

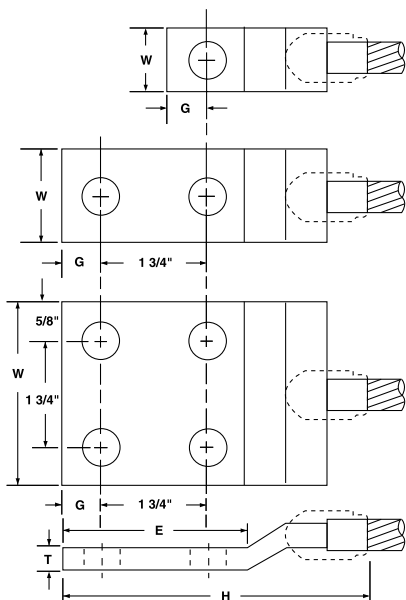

Conductor Size	Welder Part No. <sup>†</sup>	Weld Price	Weld Metal	Lug Part No. <sup>3</sup>	Lug Size	Stud Size
#8 Solid or Stranded, or #6 Solid <sup>1</sup>	CALAT-1G	CAT	CA25	CAB-101-AA	1/16X1/2	1/4
6 Stranded <sup>2</sup>	CALAT-1H	CAT	CA25			
4 Solid	CALAT-1K	CAT	CA25			
4 Stranded	CALAT-1L	CAT	CA25			
2 Solid	CALAT-1T	CAT	CA32	CAB-101-CE	1/8X1	3/8
2 Stranded	CALAT-1V	CAT	CA32			
1 Stranded	CALAT-1Y	CAT	CA32			
1/0 Stranded	CALAP-2C	CAP	CA45	CAB-101-CE	1/8X1	3/8
2/0 Stranded	CALAP-2G	CAP	CA45			

<sup>1</sup> Requires sleeve CAB-133-1L (1 per connection).

<sup>2</sup> Requires sleeve CAB-112 (1 per connection).

<sup>3</sup> Two hold lugs also available.

<sup>†</sup> Welder Part No. includes mold frame. If mold only (less frame) is required, order - Welder Part No. - "M".

In colder climates, water distribution pipes occasionally freeze in the winter. To thaw the ice, a high current (for example, from a welding machine) is applied to heat the pipe and thaw the ice. To accomplish this, each pipe joint must be efficiently bonded to control the electrical path and to prevent burning the pipe gaskets. 3/4" wide copper bonding straps, welded to the pipe with CADWELD con-

nections, provide the necessary bond or current path across the pipe joints. The bonding straps have been tested at over 500 amperes.

The straps may also be used to provide continuity for Cathodic protection or grounding systems.

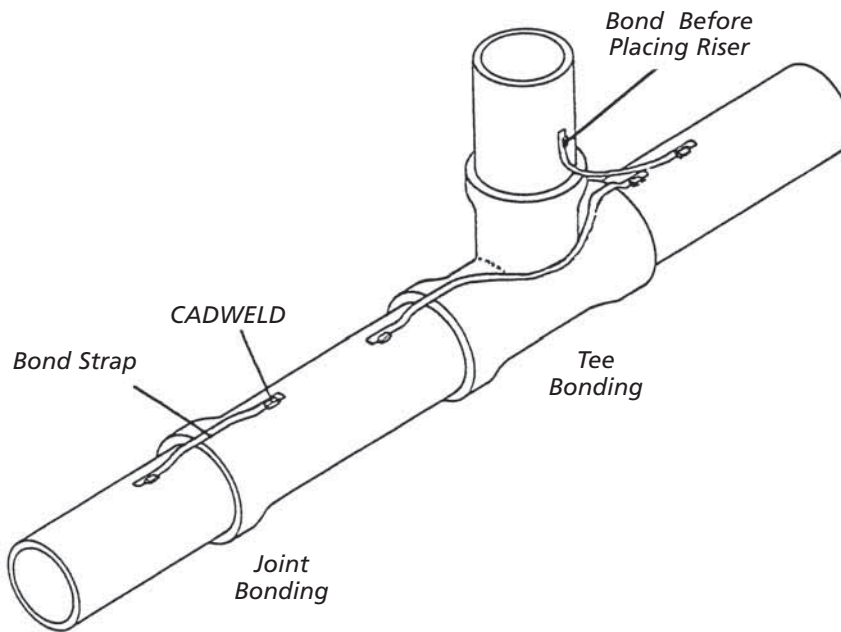

### Straps

Size	Part No.
1/16" x 3/4"	CAA817A - "L"
1/16" x 1"	CAA817B - "L"

L = Length in inches

### To Cast Iron or Ductile Iron Pipe

Pipe Size	1/16" x 3/4" Strap Mold Part No.†	1/16" x 1" Strap and Wider Mold Part No.†	Price Key	Weld Metal
4" - 12"	CACHA-ADC-A	CACHA-AEC-A	CAA	CA32XF19
14" - 30"	CACHA-ADC-B	CACHA-AEC-B	CAA	CA32XF19
Over 30"	CACHA-ADC	CACHA-AEC	CAA	CA32XF19
As Specified #	CACHA-ADC-(PS)*	CACHA-AEC-(PS)*	CAA	CA32XF19

### To Steel Pipe

Pipe Size	1/16" x 3/4" Strap Mold Part No.†	1/16" x 1" Strap and Wider Mold Part No.†	Price Key	Weld Metal
4" - 12"	CACHA-ADS-A	CACHA-AES-A	CAA	CA32
14" - 30"	CACHA-ADS-B	CACHA-AES-B	CAA	CA32
Over 30"	CACHA-ADS	CACHA-AES	CAA	CA32
As Specified #	CACHA-ADS-(PS)*	CACHA-AES-(PS)*	CAA	CA32

† Mold part number listed is mold with frame. For mold only, add suffix - M to part number (e.g., CACHA-ADC-M).

# When only one pipe size is involved, order mold to fit that pipe size.

\* Add pipe size (PS).



The CADWELD "Punched Strap" Bond allows bonding across joints of steel pipe with a bond of approximately 1/0 AWG size using a CA15 Weld Metal. This allows larger size bonds on steel pressure pipe covered by ANSI/ASME B31. (See page 16).

The Punched Strap bond is fabricated from 1/16" x 1-1/4" soft copper, allowing easy hand forming over the pipe coupling.

The 5-hole model is used on "Dresser Type" pipe couplings with two welds to the pipe and three to the coupling, made through the holes.

A 2-hole model (the 'B' dimensions are zero) is used across standard mechanical joints or across "Dresser Type" joints when the coupling does not have to be bonded.

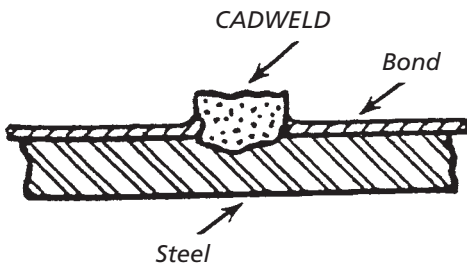
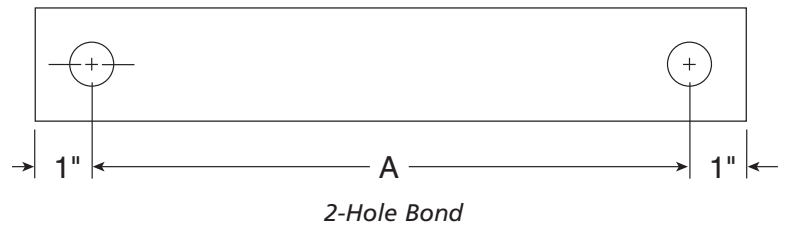
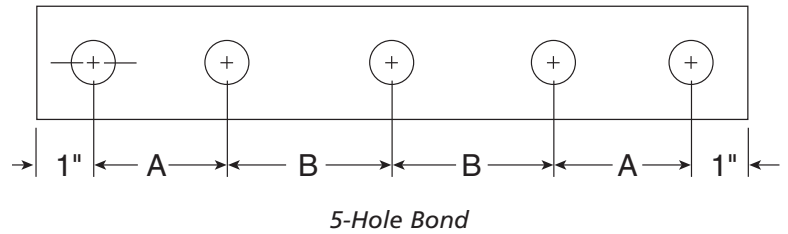
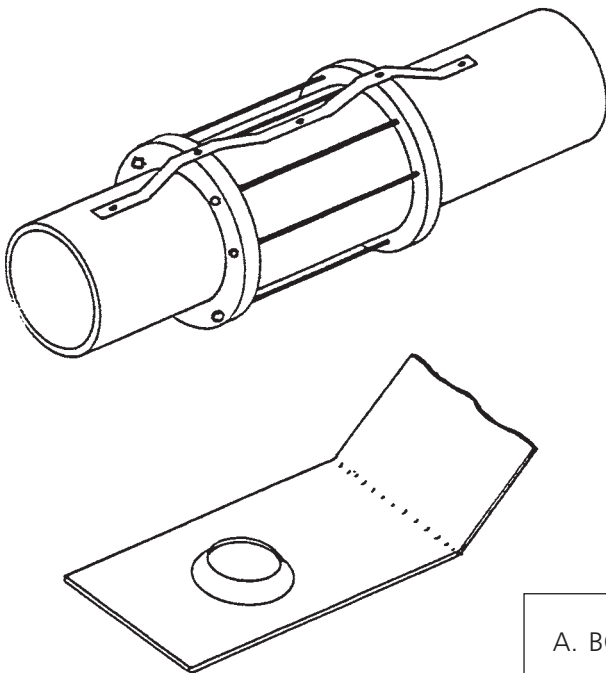

### ORDERING INFORMATION

A. BOND; CAB496A<sub>B</sub>

$\left. \begin{array}{l} \text{"B" dimension} \\ \text{"A" dimension} \end{array} \right\} \text{in fourths of an inch} \right\} 1\text{-}3/8" \text{ min.}$

Example:

- a) 5-hole bond  
 $A = 3\text{-}3/4"$  (15 fourths)  
 $B = 6\text{-}1/4"$  (25 fourths)  
 P/N CAB496A15B25
- b) 2-hole bond  
 $A = 16"$  (64 fourths)  
 $B = 0"$  (0 fourths)  
 P/N CAB496A64B0

B. CADWELD BOND;

- a) Mold with frame/Handle P/N CAHAA-AF
- b) Replacement Mold ONLY P/N CAHAA-AFM

C. CADWELD WELD METAL;  
 CA15

## FACTORY MADE BONDS

Bonds with terminals formed on the ends are often used for bonding pipe joints and fittings. The formed terminal allows a smaller weld metal size to be used.

Conductor Size	Insulated Bond Part No.	Bare Bond Part No.
#2	CAF1-1V – length in inches	CAF2-1V – length in inches
1/0	CAF1-2C – length in inches	CAF2-2C – length in inches
2/0	CAF1-2G – length in inches	CAF2-2G – length in inches

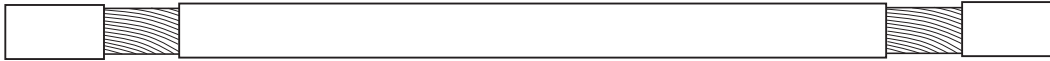

## FIELD MADE BONDS

Formed Terminal Bonds may be made in the field using sleeves (one per conductor end) and forming them in the hammer dies listed.

Conductor Size	Sleeve Part No.	Hammer Die Part No.
#4	CAS-20-F	JD11
#2	CAS-09-F	JD09
1/0	CAS-05-F	JD05
2/0	CAS-03-F	JD03

## WELDERS FOR FORMED TERMINAL BONDS

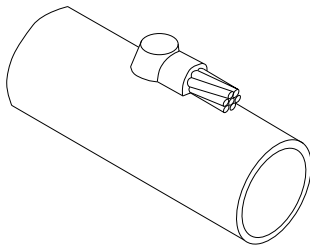

Type CAFS Welders for STEEL Pipe.

For DUCTILE IRON, see page 17.

Type CAFC Welders for CAST IRON Pipe.

Do not use on soil pipe. (ASTM A74-82).

A test weld should be made on a section of the pipe being used to determine possibility of detrimental metallurgical effects.

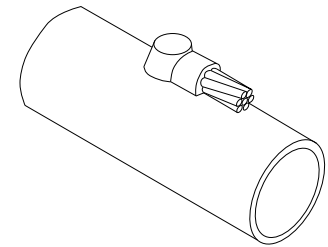

STEEL				Conductor Size	CAST IRON			
Surface	Welder Part No.†	Welder Price	Weld Metal		Surface	Welder Part No.†	Welder Price	Weld Metal
Flat (10" & larger pipe) 4" pipe 6 to 8" pipe	CAFSA-1L	CAA	CA25	#4	Flat (30" & larger pipe) 4" to 24" pipe	CAFCA-1L	CAA	CA32XF-19
	CAFSA-1LA	CAA	CA25			CAFCA-1L-PS*	CAA	CA32XF-19
	CAFSA-1LB	CAA	CA25					
Flat (10" & larger pipe) 4" pipe 6 to 8" pipe	CAFSA-1V	CAA	CA25	#2	Flat (30" & larger pipe) 4" to 24" pipe	CAFCA-1V	CAA	CA32XF-19
	CAFSA-1VA	CAA	CA25			CAFCA-1V-PS*	CAA	CA32XF-19
	CAFSA-1VB	CAA	CA25					
Flat (12" & larger pipe) 4" pipe 6 to 10" pipe	CAFSA-2C	CAA	CA32	1/0	Flat (30" & larger pipe) 4" to 24" pipe	CAFCA-2C	CAA	CA45XF-19
	CAFSA-2CA	CAA	CA32			CAFCA-2C-PS*	CAA	CA45XF-19
	CAFSA-2CB	CAA	CA32					
Flat (12" & larger pipe) 4" pipe 6 to 10" pipe	CAFSA-2G	CAA	CA45	2/0	Flat (36" & larger pipe) 4" to 30" pipe	CAFCA-2G	CAA	CA65XF-19
	CAFSA-2GA	CAA	CA45			CAFCA-2G-PS*	CAA	CA65XF-19
	CAFSA-2GB	CAA	CA45					

\* Indicate pipe size.

† Replacement molds (graphite portion) are available by ordering Welder Part No. - "M".



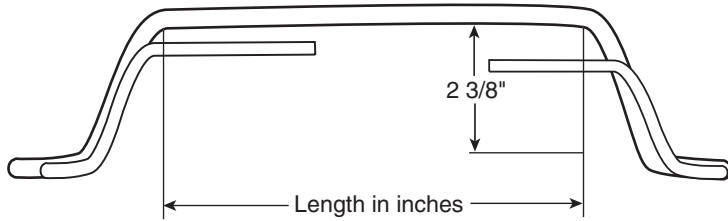

### FACTORY MADE BONDS with Pigtails for "Dresser Type" Pipe Couplings

Insulated, formed terminal bonds with insulated pigtails are used to bond across the joint and to bond both the middle ring and follower ring of Dresser Type Couplings.

Conductor Size	Pigtail Size	Bond Part No.
#2	#12 Solid	CAD1-1V-length in inches
1/0	8 Solid	CAD1-2C-length in inches

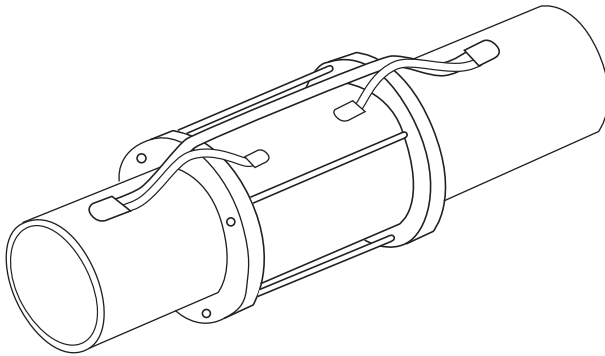

Type CADS Welders for Steel Pipe

### Type DC Welders for CAST IRON Pipe

Do not use on soil pipe. (ASTM A-74-82).

A test weld should be made on a section of the pipe being used to determine possibility of detrimental metallurgical effects.

For DUCTILE IRON, See page 17.

Bond <sup>1</sup>	Pipe Size	TERMINAL WELDER			PIGTAIL WELDER		
		Welder Part No. <sup>†</sup>	Welder Price	Weld Metal	Welder Part No. <sup>†</sup>	Welder Price	Weld Metal
<b>TYPE CADS WELDERS FOR STEEL PIPE</b>							
CAD1-1V (#2)	4" pipe 6" to 8" pipe 10" & larger pipe	CADSA-1VA	CAA	CA25	CAHAA-1G	CAA	CA15
		CADSA-1VB	CAA	CA25			
		CADSA-1V	CAA	CA25			
CAD1-2C (1/0)	4" pipe 6" to 10" pipe 12" & larger pipe	CADSA-2CA	CAA	CA32	CAHAA-1D	CAA	CA15
		CADSA-2CB	CAA	CA32			
		CADSA-2C	CAA	CA32			
<b>TYPE CADS WELDERS FOR CAST IRON PIPE</b>							
CAD1-1V (#2)	4 to 24" pipe 30" & larger pipe	CADCA-1VA-P.S.*	CAA	CA32XF-19	CAHBA-1G-P.S.*	CAA	CA25XF-19
		CADCA-1V	CAA	CA32XF-19	CAHBA-1G	CAA	CA25XF-19
CAD1-2C (1/0)	4 to 24" pipe 30" & larger pipe	CADCA-2C-P.S.*	CAA	CA45XF-19	CAHBA-1D-P.S.*	CAA	CA25XF-19
		CADCA-2C	CAA	CA45XF-19	CAHBA-1D	CAA	CA25XF-19

\* Add pipe size. Example: CADCA-1V-12 for 12" pipe.

<sup>†</sup> Welder Part No. includes mold frame. If mold only (less frame) is required, order - Welder Part No. - "M".

<sup>1</sup> For factory made bonds listed above.

# Welders and Molds

## CADWELD WELDERS AND MOLDS

When making a CADWELD connection, an accurate control of the CADWELD process is accomplished by using a semi-permanent graphite mold. Control is exercised over the direction and speed of the molten CADWELD weld metal flow and final shape. The graphite used in a CADWELD mold is a high temperature type that lasts for an average of 50 to 100 CADWELD connections under normal usage.

Welder Price CAT, CAP and CAN are split and use the new Mini E-Z Change handle.\*

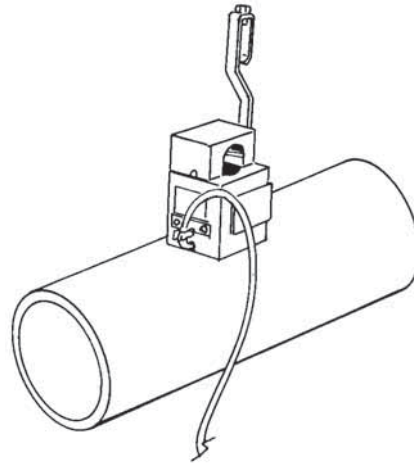
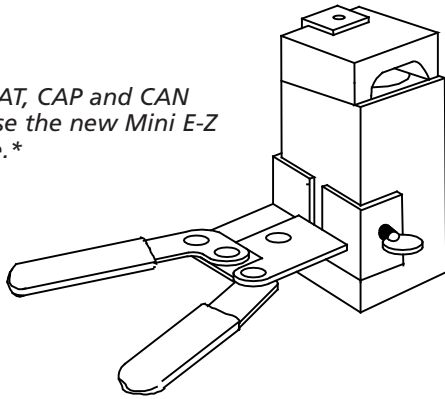

Welder Price CAA is a solid block with a hold-down handle.\*

\* Welder Part No. includes mold frame.  
If mold only (less frame) is required, order - Welder Part No. - "M".

# Weld Metal

## CADWELD WELD METAL

CADWELD weld metal is a mixture of copper oxide and aluminum, packaged by size in plastic tubes. Each tube contains the starting material at the bottom of the plastic tube, with the Weld Metal on top. These materials are not explosive and not subject to spontaneous ignition. These containers are packaged in boxes along with metal disks. Each weld uses one disk.

Two types of CADWELD weld metal are used for Cathodic protection connections:

1. F-33 alloy is used for all connections of cable to cable and cable to steel or stainless steel pipe. The F-33 weld metal containers have green caps.
2. XF-19 alloy is used for all connections to cast iron. XF-19 weld metal containers have orange caps.

NOTE: For DUCTILE IRON, see page 17.

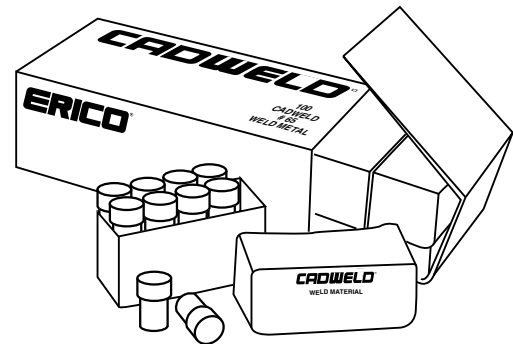

Size	PACKED PER	
	Box**	Std. Pkg.
CA15	20	100
CA25	20	100
CA32	20	100
CA45	20	100
CA65	20	100

\* XF-19 Alloy packed in same quantities.  
XF-19 Alloy not available in 15 size.  
\*\*Disks are included.





# Tools and Materials

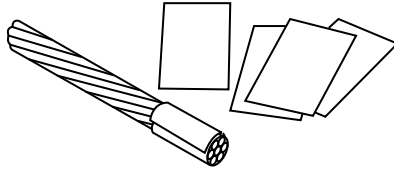

**CADWELD WRAP SLEEVE CAB140A**  
 CADWELD Wrap Sleeve is wrapped around the cable until the diameter is about the same as the cable opening in the mold.

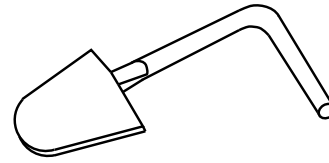

**MOLD CLEANER CAB-136-A**  
 Mold Cleaners are useful for removing the slag from CAA molds after making a CADWELD connection.

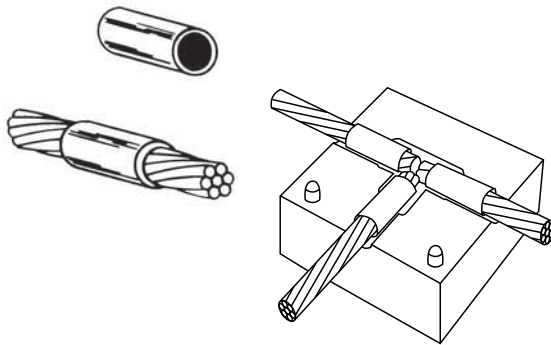

**ADAPTER SLEEVES**  
 Small conductors may be built up to fit the opening of larger size welders using either adapter sleeves or shim stock.

Cable Size		Use Adapter Sleeve Part No.	Use in Mold for Conductor Size	
Stranded	Solid		Stranded	Solid
#12, 14	#10, 12, 14	CAB-133-1H	#6	#6
10	8, 10	CAB-133-1K	--	4
7, 8, 10	6, 8	CAB-133-1L	4	--
6	5	CAB-112	2	--

Adapter sleeves can be used when a limited number of connections are to be made with a smaller conductor in a larger welder.

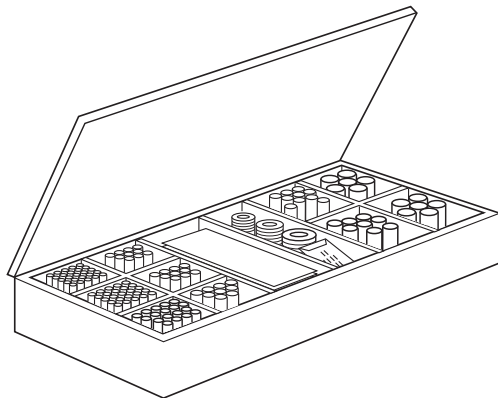

## CADWELD Sleeve Kit

T427 Includes:			
Product#	Quantity	Product#	Quantity
B1331H	25	B1332L	8
B1331L	25	B1332Q	12
B112	18	B140A	10
B1331V	10	B117A	20
B1331Y	10	B117B	10
B1332C	9	B117C	10
B1332G	10	T320A	10

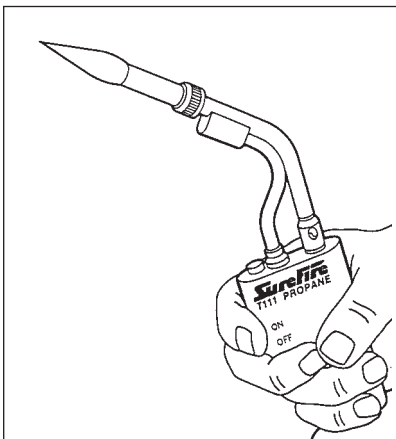

**SUREFIRE™ CAT-111**  
 Self-igniting propane torch head. Squeeze the control knob for an instant flame. Release and it's out. No flame adjusting. And, the burn tip remains cool during normal use. Operates on its side or upside down. Can withstand 60-MPH winds without flareout. Saves fuel. Safer to use. Fits all standard 14 and 16 oz. propane cylinders.  
 SUREFIRE™ is a trademark of IPI.

# Tools and Materials

EXTENSION FLINT IGNITOR

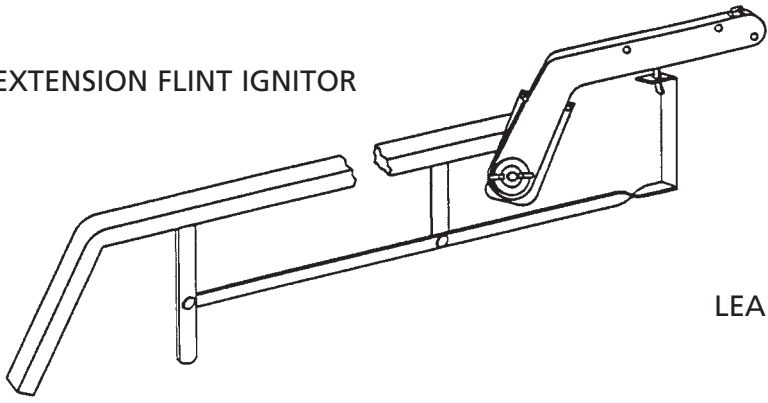

LEAD HOLDING CLIP

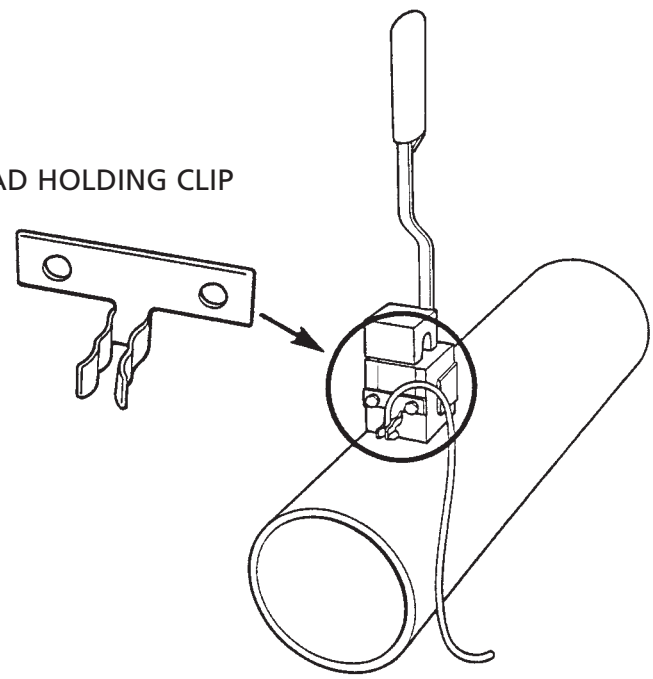

Cat. No.	Description
CAB-321-30	Extension including Flint Ignitor (30 inches long)
CAT-320	Replacement Flint Ignitor Only
CAT-320-A	Replacement Flints
CAB-322	Lead Holding Clip - Fits all CAA Price Welders

CAB-319 VERTICAL PIPE CLAMP

Holds the welder to a vertical pipe while the CADWELD connection is made. Fits all CAN, CAP or CAT price welders and pipes to 6 inches.

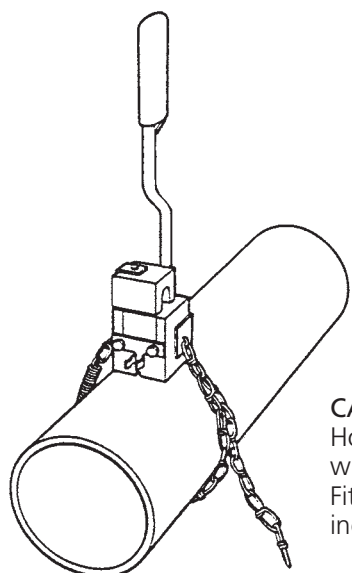
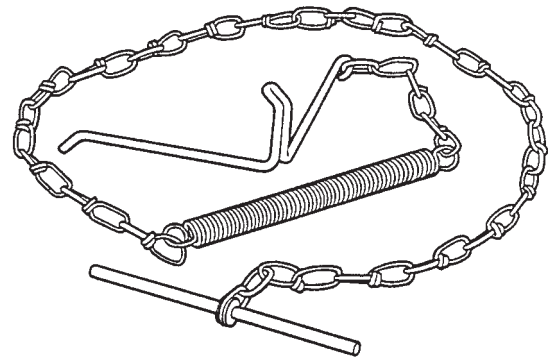
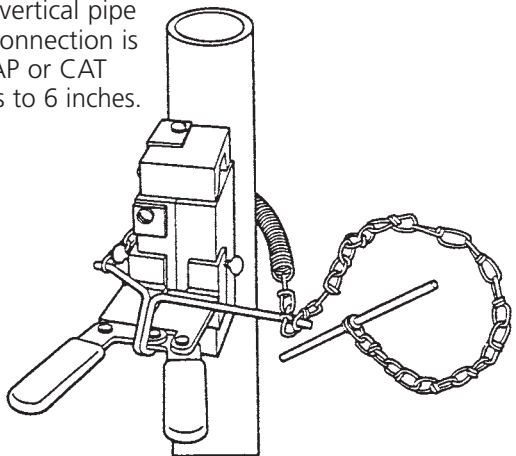

CAB-320 HORIZONTAL PIPE CLAMP

Holds the welder to a horizontal pipe while the CADWELD connection is made. Fits all CAA price welders and pipes to 6 inches.

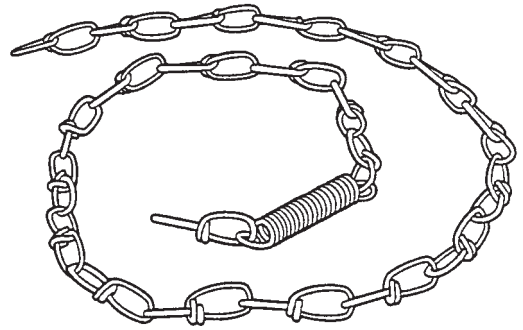

# Tools and Materials

CAT396

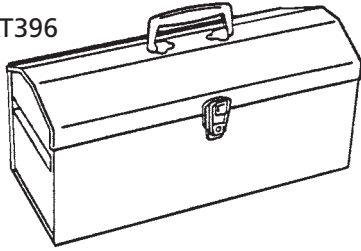

CAT321



CAT320

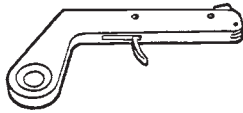

CAT305



CAT336



CAT335



CAT328

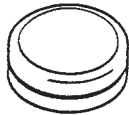

CAT329

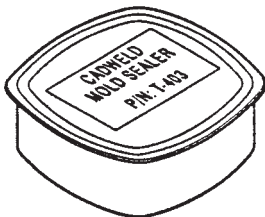

## MOLD SEALER

Mold Sealer is required around the cable on outside of the CADWELD mold for Types CAHA, CAHB, CAHC, and CAHE.

CAT-403 - 2# Package

## TOOL BOXES AND TOOLS

Item	Part No.
TOOL BOXES ONLY	CAT-396
COMPLETE KIT BOX AND TOOLS	CAT-343 <sup>1</sup>
RASP	CAT-321
Replacement blade for Rasp	CAT-321-A
Flint Ignitor	CAT-320
Screw Driver	CAT-305
Wire Brush	CAT-336
Crimping Tool	CAT-335
Disk Container	CAT-328
Card Cloth Brush	CAT-313
File and Handle	CAT-329
Mold Sealer	CAT-403

<sup>1</sup>Tools also available separately.  
<sup>1</sup>Uses tool box CAT-396

## BRUSH

The CAT-313 Card Cloth Brush is used to clean all types of copper conductors. Its short stiff bristles provide for easy removal of oxides.

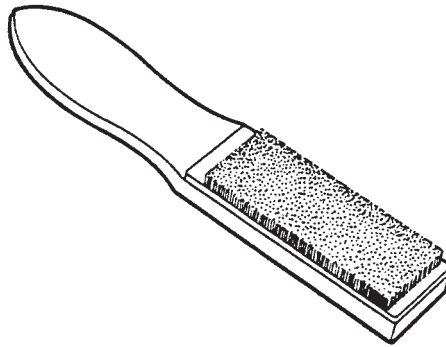

## CADWELD CONNECTIONS TO PIPELINES

1. The American Society of Mechanical Engineers\* (ASME) publishes codes relating to the design and installation of pressure piping systems:
  - 1.1. ANSI/ASME B31.8- 2000, GAS TRANSMISSION AND DISTRIBUTION PIPING SYSTEMS.
  - 1.2. ANSI/ASME B31.4- 1998, LIQUID TRANSPORTATION SYSTEMS FOR HYDROCARBONS, LIQUID PETROLEUM GAS, ANHYDROUS AMMONIA, AND ALCOHOLS.
2. In both, under Corrosion Control, the standard allows the attachment of electrical leads using exothermic welding but limits the size of the weld metal used to:
  - 2.1. CA15 for steel pipe.
  - 2.2. CA32XF19 for cast, wrought and ductile iron pipe.
3. These restrictions allow for the welding of #4 AWG and smaller wire to steel pipe using CADWELD Cathodic Type CAHA connections and #6 AWG and smaller to cast, wrought, and ductile iron using Type CAHB connections.

When larger sized conductors must be attached to pressure piping systems covered by these codes, several alternative solutions are available:

- 3.1. Using a Formed Terminal Bond (page 10), a #2 AWG can be welded to cast, wrought and ductile iron with a CA32XF19.
- 3.2. Using a CADWELD Bonding Strap (page 8), a 1/6" x 1" copper strip (equivalent to slightly smaller than a #1 AWG) can be welded to a cast, wrought and ductile iron pipe with a CA32XF19.
- 3.3. The "Punched Strap" Bond (page 9) (1/16" x 1-1/4" copper, equivalent to slightly less than a 1/0 AWG) can be welded to steel pipe using a CA15. The 5-hole model is used for "Dresser Type" couplings and the 2-hole model for standard joints.
- 3.4. The strands of a larger 7 strand conductor can be spread and each strand welded separately (figure 1) as noted in the following table:

\* Available from: The American Society of Mechanical Engineers  
United Engineering Center, 345 East 47th Street, New York, NY 10017.

FIGURE 1  
Thermite welding of larger  
7 STRAND cable to pipeline

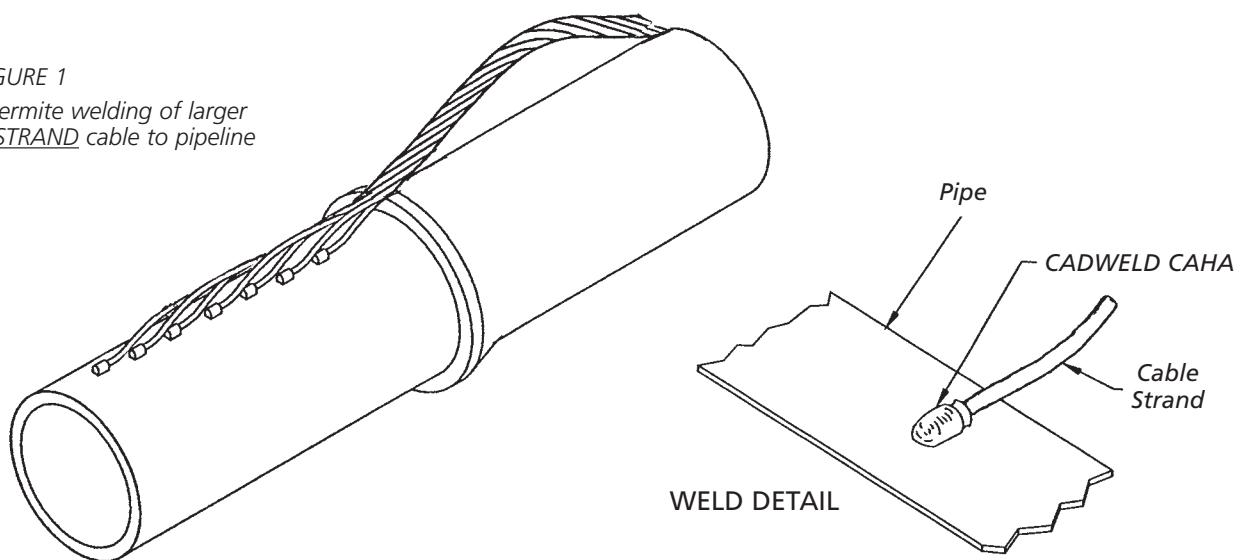

Conductor 7 Strand	Welder For Each Strand For Steel Pipe	Weld Metal
4/0	CAHAA1H	CA15
3/0 to #1	CAHAA1G	CA15
#2 to #4	CAHAA1G with sleeve B1331H	CA15

# CADWELD Connections and Pipe Wall Thickness

The following is a discussion of the minimum pipe size required for safe installation of CADWELD Cathodic Connections considering of the service conditions and without special factory testing. Several things must be considered as outlined below.

For a particular wall thickness:

- a. The hoop stress in the pipe will increase as the pipe diameter increases.
- b. The heat dissipation will be affected by the thermal characteristics of the material in the pipe.
- c. The heat dissipation will be affected by the rate of flow of the material through the pipe while making the weld.
- d. The pipe strength will be affected by the temperature of the pipe (material temperature).
- e. Any internal coating of the pipe must be checked to find if the temperature of the pipe directly under the weld will adversely affect it.

Based on a minimum wall thickness of 0.109 inches\* (2.769 mm) and using a CA15 Weld Metal (the maximum allowed to oil or gas piping systems per ANSI/ASME B31.4 and B31.8), the minimum recommended pipe size and schedule is:

<u>Nominal Pipe Size</u>	<u>Schedule</u>	<u>Wall Thickness</u>
1/2"	40	0.109
3/4"	40	0.113
1 to 2"	10	.0109
2-1/2 to 4"	10	1.120
5 to 8"	5	0.109
10" and larger	5	>0.109

Tests made by operating gas companies indicate no damage to a 4" Grade 52 pipe having a 0.109" wall when making a weld to the pipe at 500 psig using a CA15. Welds made to a steel plate 0.109" thick had a maximum copper penetration depth of less than 0.010". Other tests on tubes with a 0.125" or 0.150" wall showed a copper penetration of 0.005' maximum.

## Ductile Iron

Tests by ERICO, Inc. indicate that connections to DUCTILE IRON pipe can be made using the CADWELD molds and weld metal designated to be used on steel pipe.

However, some reports from the field suggest that all ductile iron is not the same. In some cases the material for steel will not work. In such cases, the molds and weld material for cast iron do work.

We therefore, suggest:

1. Whenever possible, make tests on the ductile iron pipe being used to determine if the material for steel can be used.

-OR-

2. Use the material for cast iron. It will make satisfactory connections on all ductile iron.

# Cross Reference

Thermoweld Part Number	CADWELD Part Number	Thermoweld Part Number	CADWELD Part Number	Thermoweld Part Number	CADWELD Part Number
M100	CAHAA1G	M156	CAHBA1G	M2001	CAGTP181L
M101	CAHAA1GA	M157	CAHBA1H	M2002	CAGTP181V
M102	CAHAA1H	M158	CAHBA1K	M2003	CAGTP181Y
M103	CAHAA1HA	M159	CAHBA1L	M2004	CAGTN182C
M104	CAHAA1K	M160	CAHBA1T	M2005	CAGTN182G
M105	Call ERICO	M161	CAHBA1V	M1927	CAPGT12CU
M106	CAHAA1L	M162	Call ERICO	M1928	CAPGT10CU
M107	CAHAA1LA	M163	CAHBA1Y	M1929	CAPGT08CU
M108	Call ERICO	M164	Call ERICO	M1930	CAPGT06CU
M109	CAHAA1T	M165	Call ERICO	M1931	CAPGT1G1D
M110	CAHAA1TA	M2594S	CAVHT1G	M1932	CAPGT06CU
M111	Call ERICO	M2594	CAVHT1H	M1933	CAPGT1G1D
M112	CAHAA1V	M2595S	CAVHT1K	M1934	CAPGT1H1H
M113	CAHAA1VA	M2595	CAVHT1L	M1935	CAPGT1L1E
M114	CAHAA1VA	M2596S	CAVHP1T	M1936	CAPGT1L1H
M115	CAHAA1VB	M2596	CAVHP1V	M1937	CAPGT1L1L
M116	CAHAA1Y	M2597S	Call ERICO	M1938	CAPGT1V1E
M117	CAHAA1YA	M2597	CAVHP1Y	M1939	CAPGT1V1H
M118	Call ERICO	M2598	Call ERICO	M1940	CAPGP1V1L
M119	Call ERICO	M2599	Call ERICO	M1941	CAPGP1V1V
M120	CAHAA2C	M1960	CAGRT151H	M1942	CAPGP1Y1E
M121	CAHAA2CA	M1961	CAGRT151L	M1943	CAPGP1Y1H
M122	Call ERICO	M1962	CAGRT151V	M1944	CAPGP1Y1L
M123	CAHAA2CC	M1963	CAGRT151Y	M1945	CAPGP1Y1Y
M124	CAHAA2G	M1964	CAGRT152C	M1946	CAPGP2C1E
M125	Call ERICO	M1965	CAGRT152G	M1947	CAPGP2C1H
M126	CAHAA2GB	M1968	CAGRT161H	M1948	CAPGP2C1L
M127	CAHGAA2GC	M1969	CAGRT161L	M1949	CAPGP2C2C
M142	CAVST1G	M1970	CAGRP161V	M1950	CAPGP2G1E
M150	CAVST1GA	M1971	CAGRP161Y	M1951	CAPGP2G1H
M151	CAVST1GB	M1972	CAGRP162C	M1952	CAPGP2G1L
M144	CAVST1H	M1973	CAGRP162G	M1953	CAPGN2G2G
M152	CAVST1HA	M1974	CAGRT181G	15P	CA15
M153	CAVST1HB	M1975	CAGRT181G	15PS	CA15S
M145	CAVST1K	M1976	CAGRT181H	25P	CA25
M186	CAVST1KA	M1977	CAGRP181L	32P	CA32
M187	CAVST1KB	M1978	CAGRP181V	45P	CA45
M188	CAVST1KC	M1979	CAGRP181Y	65P	CA65
M146	CAVST1L	M1980	CAGRP182C	15PCI	CA15XF19
M189	CAVST1LA	M1981	CAGRP182G	25PCI	CA25XF19
M190	CAVST1LB	M1982	CAGTT151G	32PCI	CA32XF19
M191	CAVST1LC	M1983	CAGTT151G	45PCI	CA45XF19
M147	CAVST1T	M1984	CAGTT151H	65PCI	CA65XF19
M192	CAVST1TA	M1985	CAGTT151L	A200	CAB1331H
M193	CAVST1TB	M1986	CAGTP151V	A201	CAB1331L
M194	CAVST1TC	M1987	CAGTP151Y	A202	CAB112
M148	CAVST1V	M1988	CAGTP152C	A203	B1332C
M195	CAVST1VA	M1989	CAGTP152G	A204	B1332L
M196	CAVST1VB	M1990	CAGTP161G	A205	B1332Q
M197	CAVST1VC	M1991	CAGTP161G	A206	B1332G
M198	CAVST1VD	M1992	CAGTP161H	A304	CAT329
M2586	CAVSP2C	M1993	CAGTP161L	A305	CAT336
M2587	CAVSP2CA	M1994	CAGTP161V	A306	CAT313
M2588	CAVSP2CB	M1995	CAGTP161Y	A309P	CAT320
M2589	CAVSP2CC	M1996	CAGTN162C	A309PI	T320A
M2590	CAVSP2G	M1997	CAGTN162G	A320	B117A
M2591	CAVSP2GA	M1998	CAGTP181G	B101	CAT321
M2592	CAVSP2GB	M1999	CAGTP181G	B101P	CAT321A
M2593	CAVSP2GC	M2000	CAGTP181H		





## **Buried Cast or Ductile Iron Pipelines**

Secure your investment by specifying the CADWELD Process for Cathodic Protection connections. The CADWELD exothermic welding process produces a molecular bond to the surface of the pipe. CADWELD connections are permanent and ensure the highest degree of electrical continuity, eliminating the potential for corrosion problems.

## **Vertical Steel Applications**

ERICO makes Cathodic Protection easy for even the most difficult vertical steel applications. We offer a comprehensive line of magnetic clamps, attachments and tools specifically engineered for the challenges of vertical steel.

## **Reinforced Concrete Protection**

Chloride contamination of reinforcing steel in concrete structures plagues many cold climate communities. To arrest corrosion, engineers specify Cathodic Protection systems for concrete road bridges and parking structures. CADWELD connections can be easily made to uneven surfaces of reinforcing steel rods for lasting protection.

## **Copper Cable Connections**

Mechanical connections for electrical cable loosen and deteriorate with age. For superior performance, specify CADWELD exothermic connections to assure a permanent, molecular bond between connecting cables for full conductivity.



**WARNING**

ERICO products shall be installed and used only as indicated in ERICO's product instruction sheets and training materials. Instruction sheets are available at [www.erico.com](http://www.erico.com) and from your ERICO customer service representative. Improper installation, misuse, misapplication or other failure to completely follow ERICO's instructions and warnings may cause product malfunction, property damage, serious bodily injury and death.

Copyright ©2009 ERICO International Corporation. All rights reserved.  
CADDY, CADWELD, CRITEC, ERICO, ERIFLEX, ERITECH, and LENTON are registered trademarks of ERICO International Corporation.