

## ESOV Series Swing Check Emergency Shut-off for Gas, Liquid, or Vapor

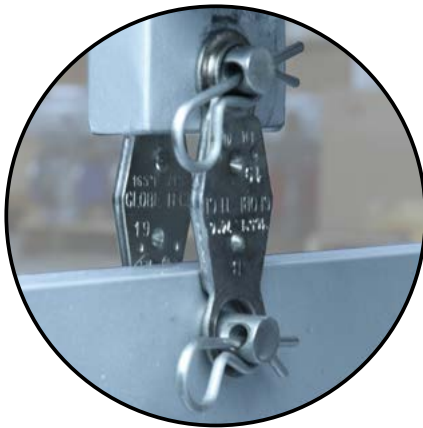

Assured Automation's ESOV series ANSI flanged swing-check valves with fusible links are designed to provide a simple yet effective method of closing in an emergency or hazardous situation.

The valves are designed with an external spring load and held in the open position with the fire-sensitive fusible link. The valve will automatically close when the link melts due to fire or high temperatures. The external lever rotates the hinge pin which drives the disc into the closed position, stopping the flow of the liquid, gas or vapor.



Dual Fusible Link

### FEATURES

- Local and/or remote actuation
- Fire-Safe fusible link
- Economical solution for required safety
- Can be used in horizontal and vertical service
- All valves are factory tested to API 598
- Back pressure ensures a tight seal between the disc and seat
- Once closed, the valve can ONLY be reset manually as a safety feature

### TYPICAL APPLICATIONS

- Refineries
- Petrochemical
- Off-shore oil rigs
- Chemical process equipment
- Water and Waste applications
- Superheated steam lines on ships

### SIZES & END CONNECTIONS

- 150# ANSI Raised Face Flanges: 2" to 16"
- 300# ANSI Raised Face Flanges: 2" to 16"

### PRESSURE RATING

- 150# ANSI Raised Face Flanges: 275 PSIG
- 300# ANSI Raised Face Flanges: 740 PSIG

### TEMPERATURE RANGE

-20°F to 475°F

### MATERIALS

- Body:** Carbon steel or Stainless Steel
- Disc:** Carbon steel or Stainless Steel
- Hanger Arm:** Carbon steel or Stainless Steel
- Seat:** API 598 Trim 8 or 12
- Cover Seal:** Graphite

[see page 2 for complete material details](#)

### OPERATION

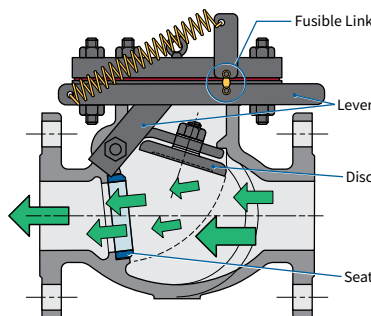

#### Normal Operation

Disc is held up and away from the seat by the lever and fusible link

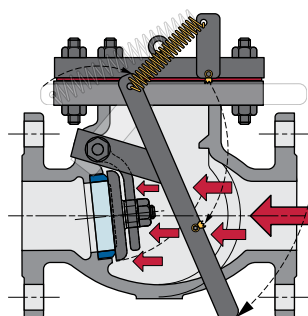

#### Emergency Shut-off

Fusible link melts and the spring pulls the lever which moves the disc into the closed position against the seat

### FLOW CAPACITIES

Size	C <sub>v</sub> (gpm)
2"	120
3"	285
4"	520
6"	1,245
8"	2,285
10"	3,570
12"	5,340
14"	6,500
16"	8,620

## ESOV



## Swing Check Emergency Shut-off for Gas, Liquid & Vapor

### BPSL

#### Basic

Spring Assisted Closure with Fusible Link Only



### CPSL

#### Pneumatic Release

Basic PLUS Pneumatic Cylinder for Trigger



### MPSL

#### Electric Release

Basic PLUS Electro-Magnetic Trigger



## ORDERING INFORMATION

## ESOV - 0200 - BPSL - 150 - C - 08 - 165F

Size	Trigger Type	Flange Class	Body Material	Trim Material	Trim Material
Size: _____					
<b>0200</b> = 2" <b>0300</b> = 3" <b>0400</b> = 4" <b>0600</b> = 6" <b>0800</b> = 8"  <b>1000</b> = 10" <b>1200</b> = 12" <b>1400</b> = 14" <b>1600</b> = 16" *Call for Larger Sizes					
Type & Remote Triggering: _____					
<b>BPSL</b> = Basic Spring Assisted Closure with Fusible Link Trigger <b>CPSL</b> = Spring Assist Closure w/ Fusible Link Trigger PLUS Pneumatic Cylinder Remote Trigger <b>MPSL</b> = Spring Assist Closure w/ Fusible Link Trigger PLUS Electro-magnetic Remote Trigger					
ANSI Raised Face Flange Class (to ANSI B16.5): _____					
<b>150#</b> = ANSI Class 150# <b>300#</b> = ANSI Class 300#					
Body Material: _____					
<b>C</b> = Carbon Steel (ASTM A216 Gr WCB) <b>S</b> = Stainless Steel					
Trim (Seat Ring) Material: _____					
<b>08</b> = API Trim 8 <b>12</b> = API Trim 12					
Trigger Temperature of Fusible Links: _____					
<b>135F</b> = 135°F <b>165F</b> = 165°F (standard) <b>212F</b> = 212°F <b>280F</b> = 280°F <b>360F</b> = 360°F					